

# DRAIN MASTER INSTALLATION INSTRUCTIONS

## PLEASE, BEFORE YOU TRY IT YOUR WAY – TRY IT OUR WAY

Our valves install differently than manual valves, please read instructions before you begin installation. **KEEP INSTRUCTIONS**

### WHAT YOU WILL NEED TO DO THIS INSTALLATION:

- Basic mechanical/ electrical knowledge
- 7/16" wrench/socket
- Drain Master DM20-RP or DM20-RPMS kit, includes: Valve, operator switch, seals, nuts, bolts, Dow 111 lubricant & Instructions.
- 12 VDC power source (for switch connection)
- 5 AMP in-line glass type fuse (not included—available at auto stores)
- Electrical connectors are provided on the valve & the switch to show proper wire hookup. Mating extension cables are not included in kit but are available for purchase. Available in 2', 4', 6', 8' & 10' lengths. If you do not want to purchase extension cables, you can extend the cables as you see fit. Wire minimum: 20 gauge

### SPECIAL NOTES:

- Make sure you have good access to the manual override wherever you choose to install your valve.
- Do not place fingers in running area of valve.
- Installation is simple and can be accomplished in a short time.
- Never install the Drain Master with the motor/gear/gate housing down. Must be installed vertically (see how to install picture below)
- PLEASE DO NOT OPERATE Drain Master prior to installation on the RV. The gate has a sharp edge and the motor is powerful and very fast. YOU COULD GET HURT. You assume liability for your actions.
- Valve now comes supplied with 1/8" Allen wrench to operate manual override – located on back of valve
- Do not use any other lubricant than the DOW 111 we have provided.
- Please follow installation instructions carefully.

## VALVE INSTALL INSTRUCTIONS

**Step 1: EMPTY AND FLUSH HOLDING TANKS!! This will make your installation an uneventful success.**

**Step 2:** Remove the four bolts holding the existing manual dump valve to plumbing.

**Step 3:** Separate plumbing enough to remove existing manual valve.

**Step 4:** Remove the 2 seals from pipe flanges or from existing manual valve.  
**IMPORTANT \*\* the old seals will not work with your new valve. \*\***

**Step 5:** Clean pipe flanges, check for cracks, replace flange if necessary. Remove caution card from gate area on new valve.

**Step 6:** Make sure valve is in the closed position before proceeding to next steps. (Valve is shipped with the gate closed)

**Step 7:** Now you are ready to install the new valve. **IMPORTANT! Use the seals that came with your new valve.** Note: Seals will be found installed on valve, please remove. Place the seals over the flange lip which is located on existing plumbing, DO NOT KEEP SEALS ON VALVE \*\*\*\*\* VERY IMPORTANT STEP\*\*\*\*\*

**Step 8:** Apply supplied lubricant (Dow 111) to both sides of gate.

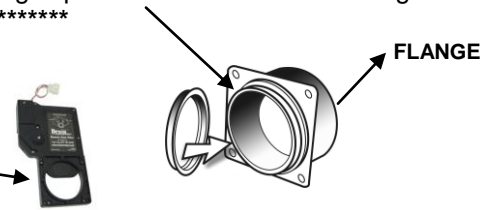

**Step 9:** Separate pipe flanges and insert Drain Master **with gates closed** making sure the seals are in their correct position **on the flanges.** See Step 7. Rotate the valve to align the four bolt holes with the flange holes and insert the four new bolts and nuts. See picture below:



**Step 10:** Install the four bolts and hand tighten. Use a 7/16" wrench and in a crisscross pattern, snug the nuts down 1/4 turn at a time. Tighten the four bolts evenly, being careful not to over tighten. The components are plastic and can crack. The tightening spec is 20 inch pounds.

**Step 11:** Add water to holding tank and check for leaks.

### NOTE: HOW TO INSTALL

**If you have questions or need help with an install, please call us toll free.**

**DRAIN MASTER  
877-787-8833  
www.drainmaster.com**

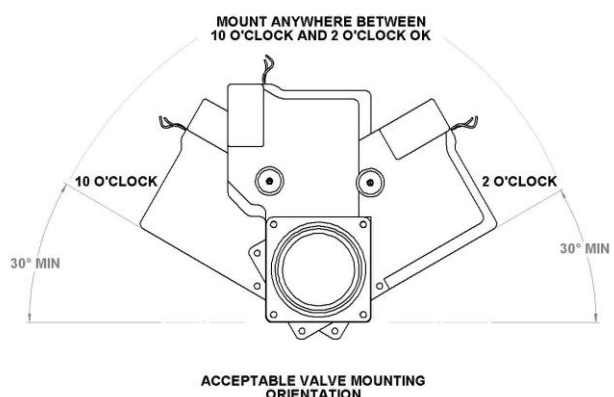

## OPERATOR SWITCH INSTALLATION INSTRUCTIONS



5008-DM30-EP-O Switch (Basic)  
for use with 5201 DM20-RP



5528-HD-DM30-LED-O Heavy Duty LED Switch  
for use with 5202 DM20-RPMS

1. If you purchased the DM20-RP kit, you will insert the switch through the black switch plate making sure the red and white wires on the switch are on top toward open. **\*\*Red & white wire must be on top toward open, or your valve will operate in the opposite direction\*\***
2. Install the switch in a convenient location on your coach, mount with the four screws (included)
3. You will need to install a 5 AMP in-line glass-type fuse to protect the motor. **\*\*\*The fuse needs to be in line between the battery positive source and the switch. You may use an existing spare fuse on a fuse block or use an in-line type.**

**Note:** Connectors are provided with the enclosed DM20-RPMS Drain Master kit to show proper wire hookup between switch and valve. You may purchase extension cables with mating connectors by calling our toll free number – 877-787-8833. Cables are available in 2', 4', 6', 8', and 10' lengths. Or you may extend the cables to as you see fit. **Wire minimum: 20 gauge**

If you choose to cut off the connectors and hard wire your operator switch to the valve, please use following wiring instructions:

### IMPORTANT – CONNECT –

- Black lead on switch – fused connect to positive 12VDC only
- Green lead on switch – connect to negative (ground)
- Red wire from switch – connect to red wire on valve
- White wire from switch – connect to white wire on valve
- If you have the LED switch version, there will be a 4 pin plug to connect to the valve. It also has the mating plug on the valve or extension cable. See schematic below. You can also visit our web site for a larger viewing of this diagram ([www.drainmaster.com](http://www.drainmaster.com))

The diagram below is available on our website at [www.drainmaster.com](http://www.drainmaster.com), under product specs.

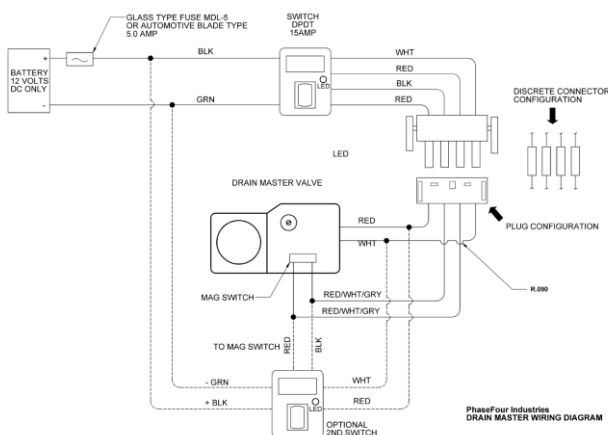

### NEW FEATURES

- If you have purchased the DM20RP and wish to upgrade to the LED version, remember it is easier to use the upgrade kit before the valve is installed. (Call 877-787-8833 to find out about upgrade)
- Double Sided manual override with hex head. **Allen Wrench is provided with the valve – secured on the back of the valve.** Make sure you install your valve with easy access to the manual override.
- Should you ever lose power to your RV, you can open/close the valve manually. Just locate the provided 1/8" Allen Wrench on the back of the valve, insert wrench in the hex head opening, the words open/close with directional arrows will show you which way is open and which way is closed. **There will be resistance when turning as you are overriding a safety clutch.** Turn until shaft stops. When convenient, check and correct electrical problems. (A stripped override caused by excessive use is not covered under warranty.)
- **NOTE:** Unless you have specifically ordered a heavy duty operator switch for your valve, the switch is not weatherproof and should be mounted in an area protected from moisture. Weatherproof switches are available for purchase.

### DRAIN MASTER WARRANTY

#### What is covered and for how long

Congratulations on your purchase of a quality product from Drain Master. We are confident that our product will perform and therefore warrant to you, as the original purchaser, for a period of 1 year from the date of original purchase, that your new product will be free of mechanical and electrical defects in material and workmanship.

#### What Drain Master Will Do & How to Get Service

If your product is covered during the warranty period, we will replace your new product (you pay shipping costs), which will be your exclusive remedy under this warranty. **Proof of purchase is required.**

Drain Master Shall not be liable for any special, incidental, indirect or consequential damages whatsoever (including, without limitation, labor or installation charges, damages for loss of business profits, business interruption or any other pecuniary loss) arising out of the use of or inability to use the product. You may return the product to your retailer or directly to Drain Master. If the retailer is unable to authorize an exchange of the product, please call us toll free for a return authorization number and shipping instructions. Items returned without an RMA # will be refused at the point of delivery.

**Send To: Drain Master, 400 Park Center Drive Ste 6, Hollister, CA 95023**

Please be aware that use of the product on improper voltage or current, use contrary to operating instructions, or disassembly, repair, or alterations by any person other than a reputable RV service station may render your product warranty void.

#### How Your State's Law May Apply

Some states do not allow limitations on how long an implied warranty lasts or the exclusion or limitation of incidental or consequential damages, so the above limitation may not apply to you. This warranty gives you specific legal rights, and you may also have other rights, which vary from state to state or province to province.

### DRAIN MASTER OPERATING INFORMATION

**Note: Do not hold the switch down longer than 2 seconds**

Congratulations on your purchase of a quality product from Drain Master. Your new Drain Master valve is extremely easy to use but may require maintenance. After installation has been completed according to the installation instructions you are ready to open the Drain Master for the first time.

Push the switch up toward the word "open" and listen for the Drain Master to make a sound. The Drain Master will open in approx. 1-2 seconds which means you do not have to hold the switch in the open position for more than 2 seconds.

**NOTE:** If the valve does not open, check to be sure you have 12VDC to the black wire and that the green wire is ground (if hard wired). Check to see that the unit does not open when you push the switch toward the "close" position. If this happens your switch is upside down. Be sure you have not over tightened the four bolts holding the Drain Master to the couplings and that the seals were installed correctly.