



P.O. Box 2316
Hollister CA 95024-2316

Waste Master™ (WM-6) Waste Evacuation System Installation / Operation Manual

The new Waste Master Kit you are about to install is simply the safest, simplest and sanitary system on the market today.

This system makes emptying the holding tanks as simple as putting gas in the car.

No more mess or contact with waste from the tanks...and it's environmentally friendly.

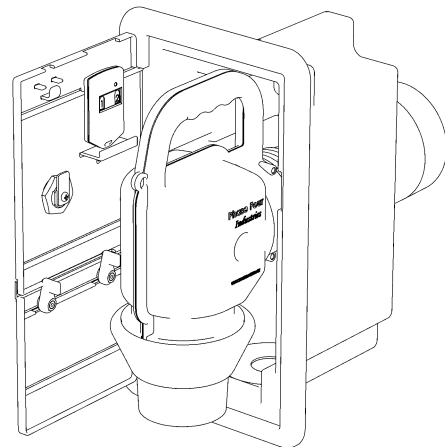
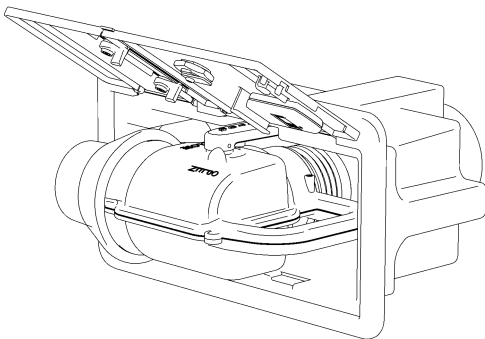

Receiver / Key Fob Serial # _____ Coach Serial# _____

NOTICE

The information in this guide is subject to change without notice. Parts illustrated are representative and are subject to change.

Drain Master Industries shall not be liable for technical or editorial errors or omissions nor for incidental or consequential damages resulting from the furnishing, performance, or use of this material.

This guide contains information protected by copyright. No part of this guide may be photocopied, reproduced, transmitted, or stored in any form without prior written consent from Drain Master Industries.

© Copyright 2004-2010 Drain Master. All rights reserved. Printed in the U.S.A.

Waste Master™, Sewer Master™, and Drain Master™ are trademarks of Drain Master Industries.

Product names mentioned herein may be trademarks and/or registered trademarks of their respective companies.

Table of Contents

<u>Introduction</u>	4
Product Overview	4
Listings	4
<u>Components Supplied With Kit</u>	5
Additional Parts Required	6
<u>System Diagrams</u>	7
Plumbing Diagram	7
<u>Installation</u>	10
Before Installing the Waste Master System	10
Installing The Enclosure and Storage Tube	10
Installing the Holding Tank Valves	12
<u>Wiring</u>	12
Valve Orientation	15
<u>OPERATION</u>	15
Extend Retract Module Installation	18
Receiver Module Mounting	19
<u>Initial System Test</u>	20
Valves and Switches	20
Receiver Module	20
<u>Operation</u>	20
Extending the Hose and Nozzle	20
Flood Testing The Holding Tank System	20
Retracting the Hose and Nozzle	21
Valve Test Unit Instructions	21
Calibrating Tank Monitors	21
What the Customer will do	22
Remote Control Programming	22
Testing valves	23
Nozzle enclosure	23
Extend Nozzle & Hose	23
<u>Troubleshooting</u>	24
Waste Master	24
Drain Master	25
<u>Replacing the Magnetic Switch</u>	26
<u>Care and Installation</u>	26
<u>A Word About the Sewer Hose</u>	28
<u>Field Changing Of Waste Master Nozzle</u>	29
<u>Warranty Information</u>	30
Information About Returns	30
Warranty	30

Introduction

Product Overview

Waste Master brings a whole new era to the RV Industry! In the past emptying holding tanks was the “least desirable task” in the life of an RVer. Not any more! Now emptying holding tanks is as simple as putting gas in the family car!

No more getting the hose out, adding fittings (that don't have handles), removing and cleaning the hose before storing it away.

Waste Master is totally sanitary because the user is not exposed to waste at any time during the waste evacuation process.

Waste Master comes with many features. The top quality Sewer Master Hose and nozzle extend a full 16-19' from the RV! The nozzle features a sanitary handle and a compression donut to insure no sewer gasses escape and the swivel on the nozzle allows the nozzle to be laid on its side when needing an extension hose added to the nozzle.

We are constantly looking for ways to improve our products and welcome your thoughts.

Listings

ANSI A119.2 LISTED



Components Supplied With Kit

1. Waste Master 6 Enclosure Assy, Qty 1
 Enclosure Keys Qty 2
 Waste Master Door / Frame Assy without magnet (if equipped)
 Waste Master Door/Frame Assy with magnet (standard)

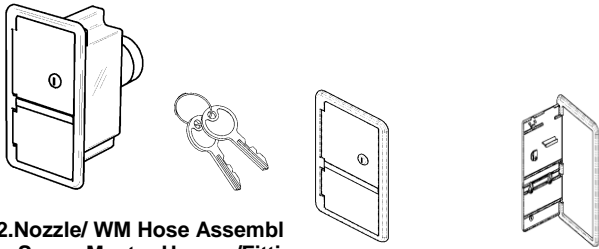

2. Nozzle/ WM Hose Assembl
 Sewer Master Hose w/Fitti
 Sewer Supreme Hose w/Fitting (if equipped)
 Waste Master Nozzle Assembly
 Waste Master Nozzle Donut Seal

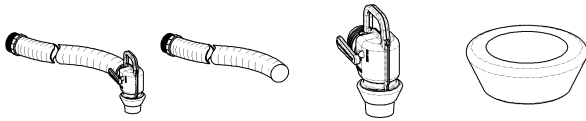

3. Storage Tube 4", Qty 2 – 37.5" ea (if equipped)

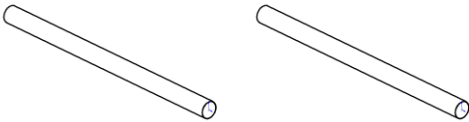

4. 4" Storage Tube Coupling, Qty 1 (if equipped)
 NOTE INTERNAL RIB FEATURE



5. 4" Slip Storage Tube Coupling, Qty 1 (if equipped)
 NO INTERNAL RIB



6. Drain Master Electric Valve Assembly, Qty 2
 Includes Spigot Hub, Male or Flange Hub, Female

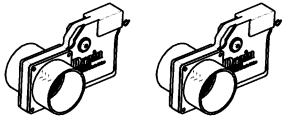

7. Valve Wiring Harness, Qty 2

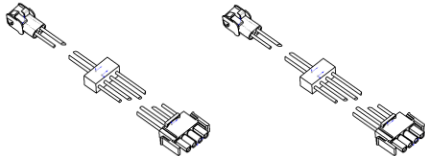

8. Drain Master Switches with LED / electrical plugs and mounting screws and labels, Qty 2

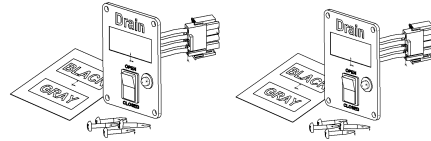

9. Extend Retract Module, Qty 1

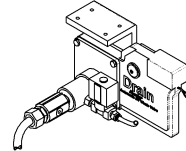

10. Air Supply Tubing Assy, Qty 1



11. Waste Master Wiring Harness, Qty 1

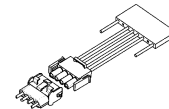

12. 15' Cable Assembly or
 8' Cable Assembly



13. Electronic Receiver, Qty 1
 WM Antennae for receiver, Qty 1

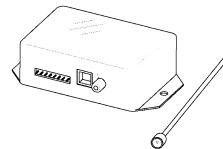

14. Remote Key Fob, Qty 1



15. OEM Installation / Operation Manual on CD, Qty 1



16. Optional: ARC1 – Air Regulator
 ARS2 – Air Regulator

Additional Parts Required

1. Regulated air supply, 70 – 110 PSI, operating pressure 6 cfm @ 40-60 PSI.

NOTE

You can order model ARC-1 or ARS-2 air regulators from Drain Master. See illustration below

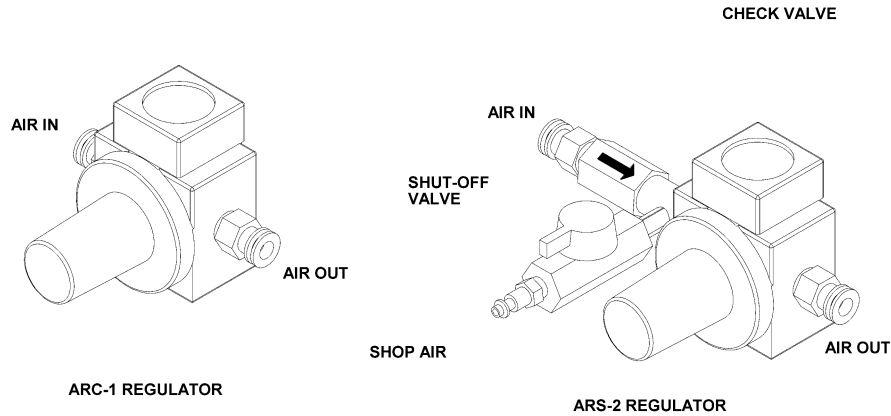

2. 3" ABS pipe & fittings to connect dump valves to manifold and tank. This configuration will vary from RV to RV installation.
3. 1/4" air pressure line from the coach regulated air supply to extend retract module.

NOTE

On ARS2 regulator, shop air port should face down & be accessible.

NOTE

Immediately contact Drain Master Industries 877-787-8833 if any parts are missing or damaged.

NOTE

IMPORTANT – Air Source to regulator must be connected to proper coach air supply tank.

System Diagrams

Plumbing Diagram

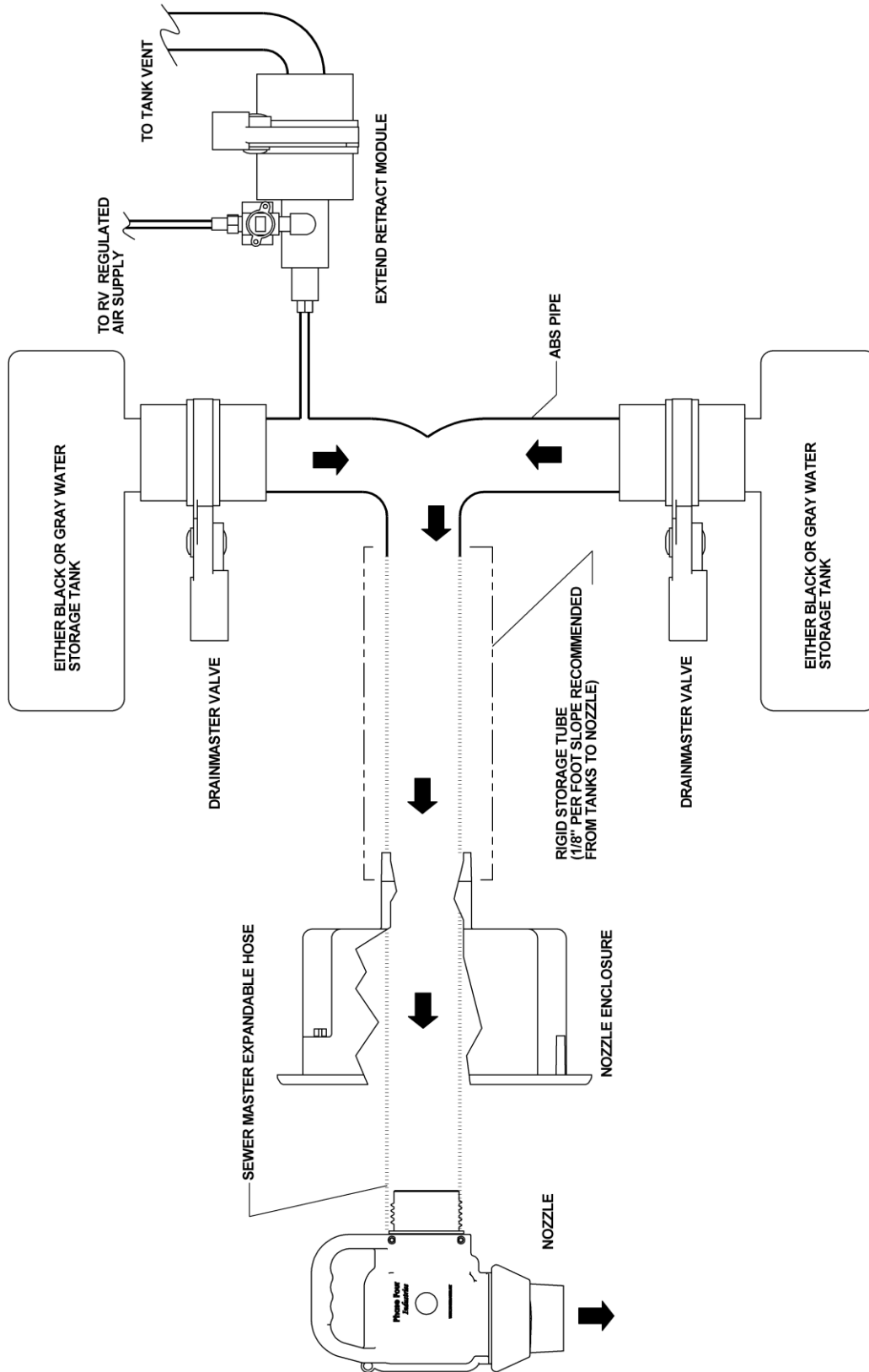

System Diagrams

Wiring Diagram

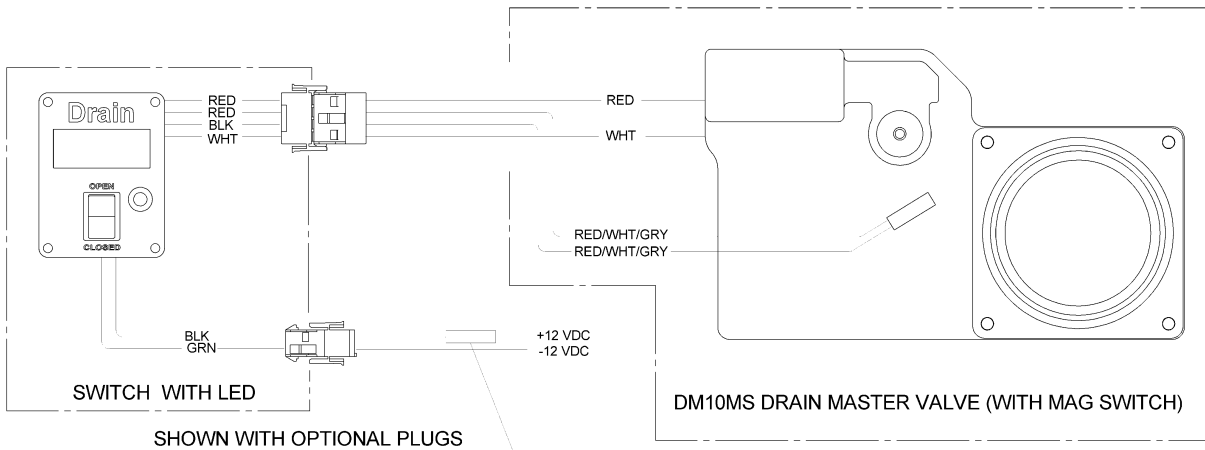
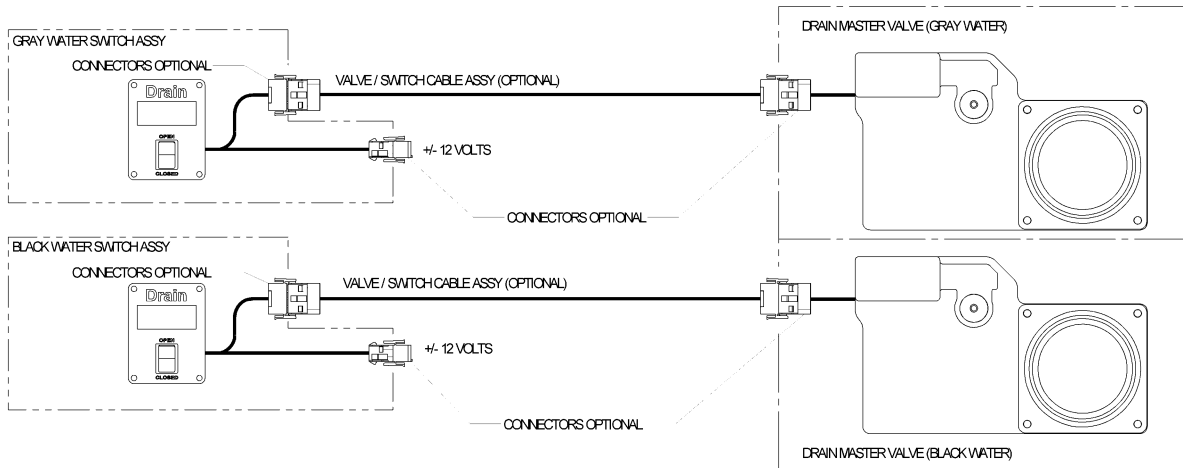
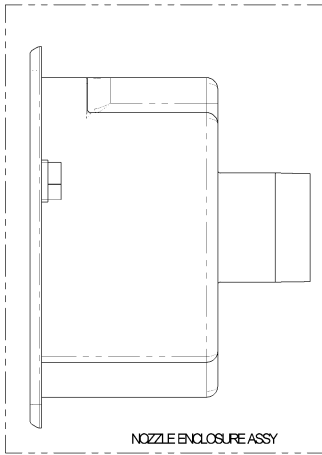

GLASS TYPE FUSE MDL-5 OR
AUTOMOTIVE BLADE TYPE 5.0 AMP

NOTE

Each valve must be fused separately for proper operation.

Mechanical Diagram

NOTE Actual manifold configuration will vary. Item numbers are referenced in the "Installing the Enclosure and Storage Tube" section.

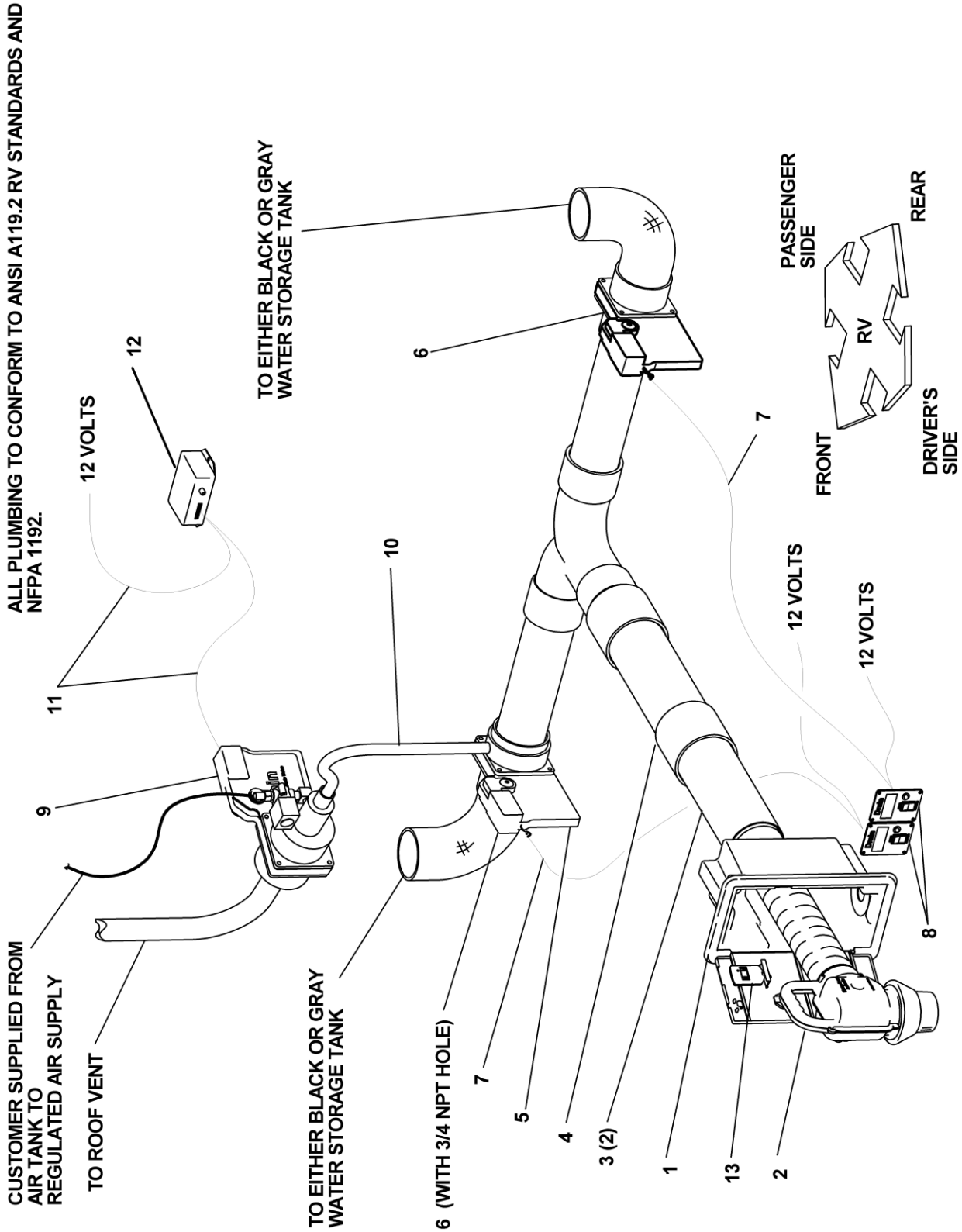

Installation

Before Installing the Waste Master System

Read this manual in its entirety. Become familiar with the system operation and installation. Also be sure you have the production engineering drawings for the RV model you are installing the system on. This drawing contains important information on component placement, special directions and things to look for on the model RV on which you are installing the system.

Installing the Enclosure and Storage Tube

Refer to the production engineering drawing for the proper placement of the two storage tubes and enclosure. The storage tube arrives in two parts. The standard installation kit contains two 4" couplings, one with a rib in the center, and one without (items 4 & 5). The item 4 coupling with the rib is used to join the two 4" tubes together using all-purpose glue. Item 5 coupling without the rib, slips over the end of the storage tube opposite the enclosure. Glue the tubes together with the item 4 coupling, and then slide the storage tube into place, as shown on the Production Engineering Drawing. Next insert the enclosure in the 4" storage tube on the driver's side of the coach and push together firmly. **DO NOT GLUE** the storage tube and enclosure together. Do not secure the enclosure to the coach frame at this time, as the dress panels will need to be fitted at a later time. When the enclosure is mounted, be sure to provide a flat surface to mount to. Irregularities may result in inadequate attachment of the frame / door assembly. The storage tube (two 37.5" tubes together) needs support other than the attachment at the enclosure. Also, allow about 2.5" of space between the end of the storage tube and the 3" female coupling that the Sewer Master hose threads into. This is for service access to the Sewer Master hose. Storage tube should be sloped from storage tanks to nozzle enclosure a minimum of 1/8" per foot per ANSI 119. See illustrations below. **NOTE: After final enclosure/storage tube installation – fit up making sure storage tube is pushed over the enclosure; secure the storage tube using 4" outside clamp so storage tube can not move. Do not screw into storage tube or enclosure. Inside of storage tube must be smooth with no burrs/screws, etc inside.**

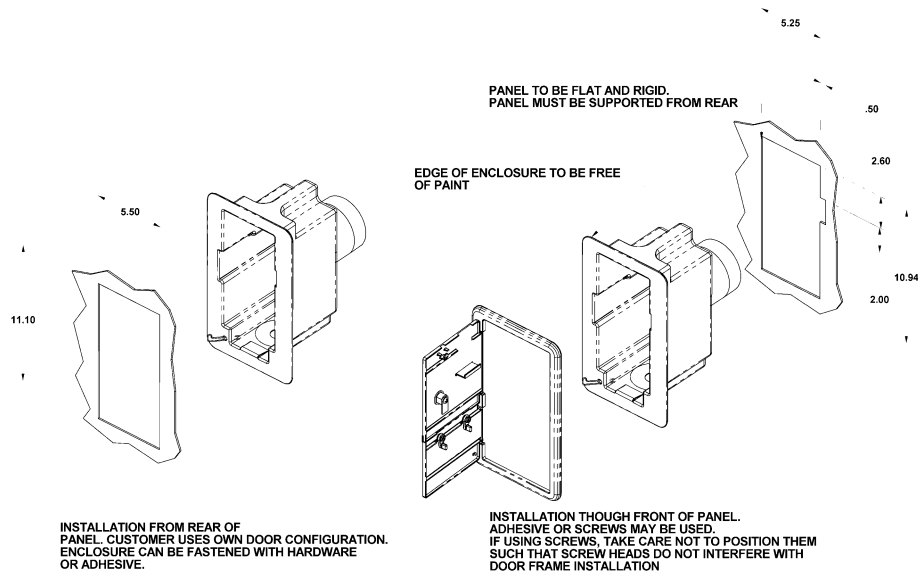

Install Frame / Door Assembly by first rotating the frame 90 degrees in relation to the enclosure, squeeze the detent spring and insert it in the hole in the enclosure, rotate frame to align with enclosure and then snap fit the frame to the enclosure. See illustration below.

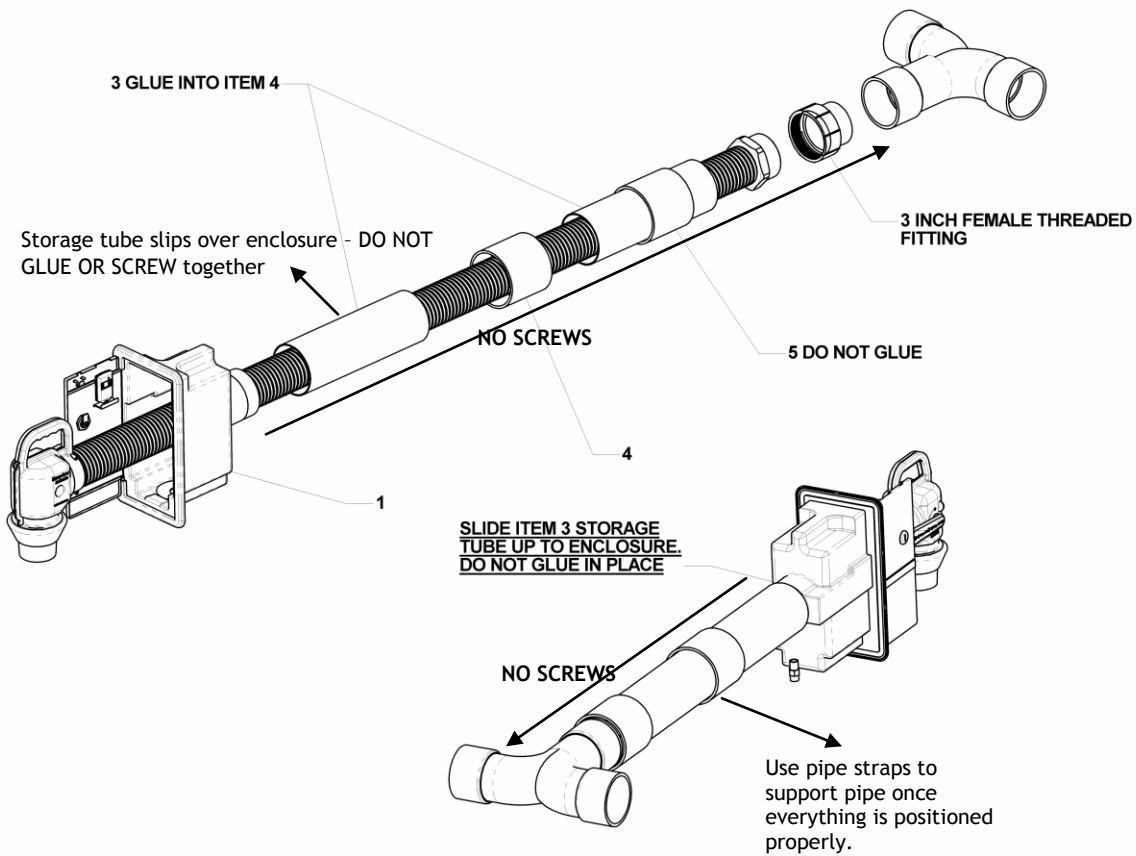
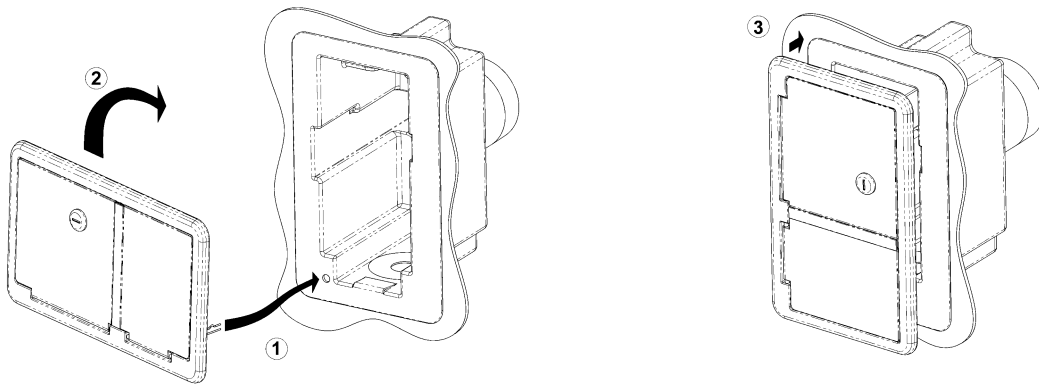

Storage tube assembly

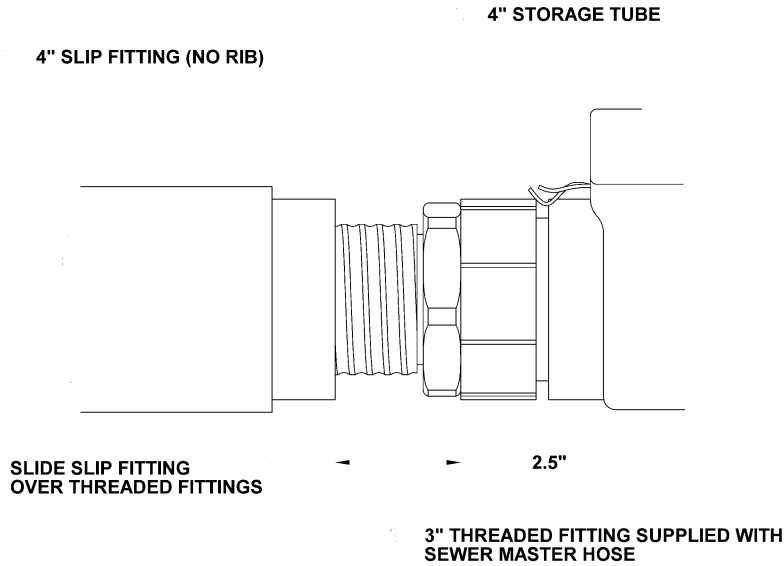

Slip fitting reveals threaded fitting for service access (shown in open position)

Installing the Holding Tank Valves

Refer to the production engineering drawing for proper location and configuration. The valves come with the hub and or spigot flanges installed. Do not remove these parts as they have been tested at the factory to insure they perform properly. If you need different configurations, please let us know and we will take care of it for you. The valves also come with the electrical plugs so an installation is a simple matter of Plug n Play.

Wiring

The Drain Master valves and switches may have been pre wired (option) using Mate-N-Lok style plugs and need only to be plugged into each other (sometimes through a corresponding harness) See illustration.

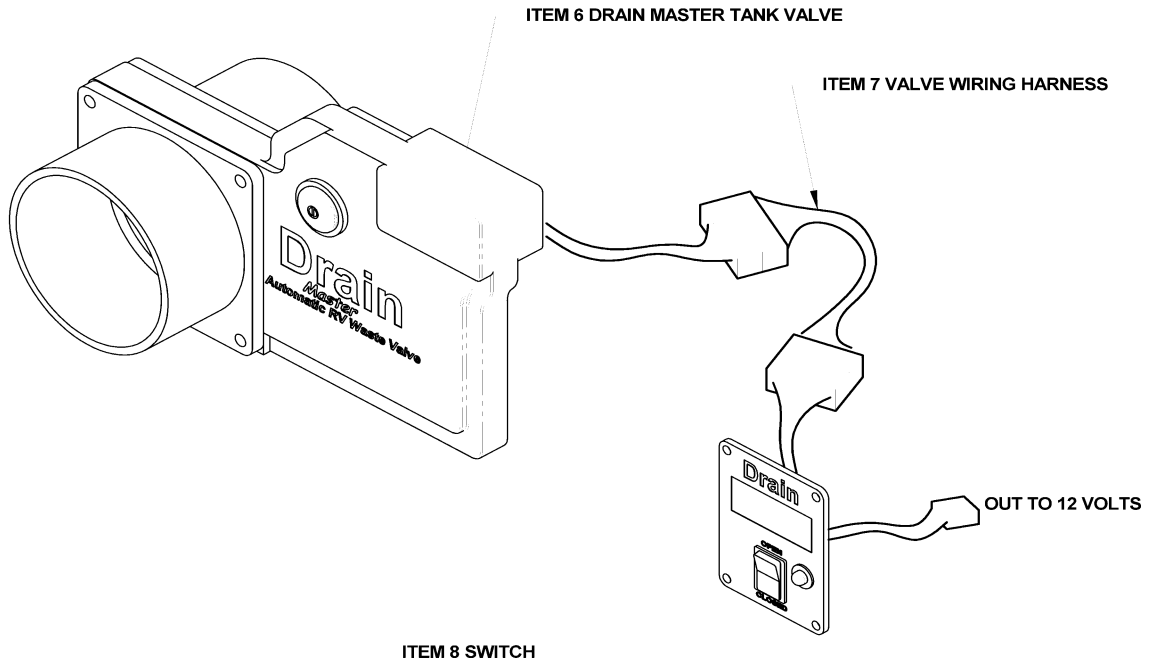

NOTE

Unless you have specifically ordered a weatherproof switch for your valve, the switch is not weatherproof, and should be mounted in an area protected from moisture. A weatherproof switch is available for purchase.

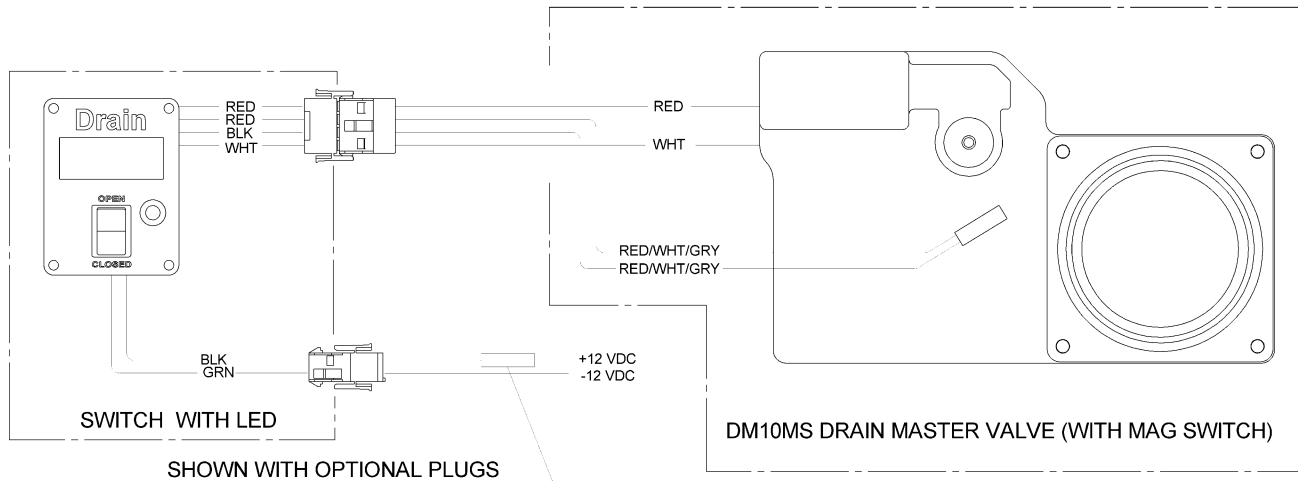

GLASS TYPE FUSE MDL-5 OR
AUTOMOTIVE BLADE TYPE 5.0 AMP
Wiring Diagram

NOTE

Switch should not be installed inside RV living space.

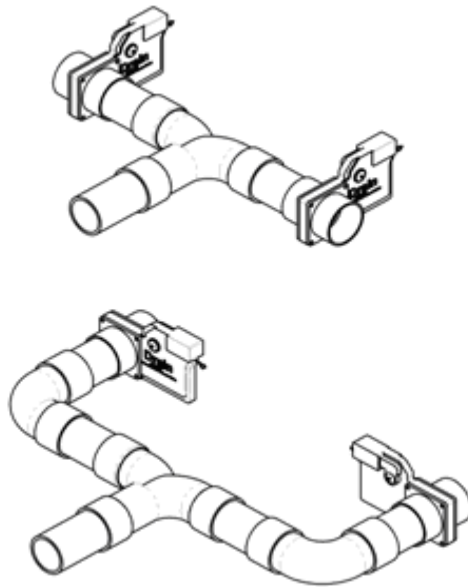

CORRECT MANIFOLD CONFIGURATIONS

NOTE

It is recommended the valve manifold be sub assembled prior to installation. If the manifold is built on the coach, there is a chance the manifold will vary coach to coach, resulting in the hose nozzle not resting in the enclosure properly.

NOTE

There should be at least 1/8" per foot slope between the manifold and the nozzle enclosure.

Valve Orientation

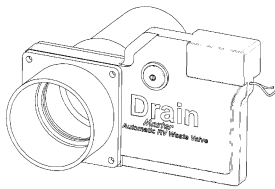
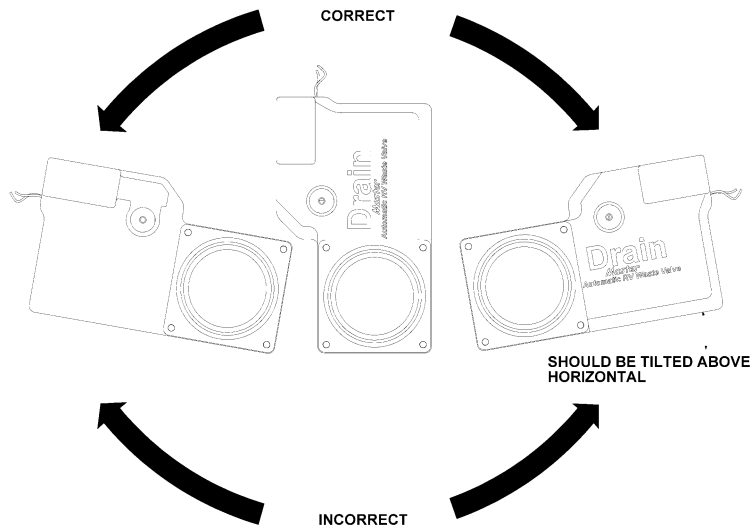

CORRECT

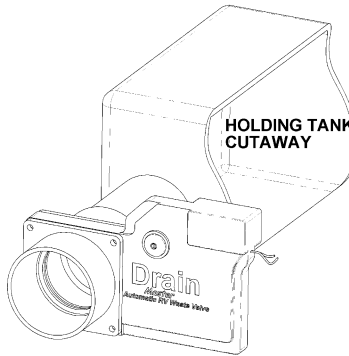

CORRECT

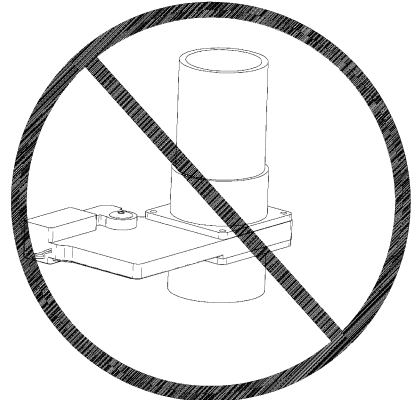

INCORRECT

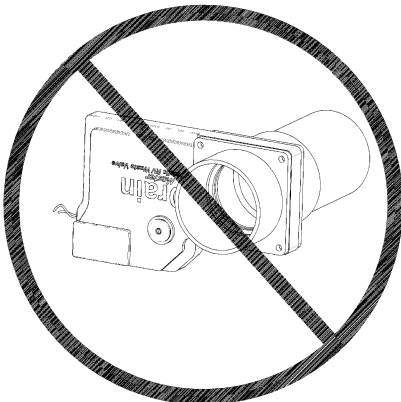

INCORRECT

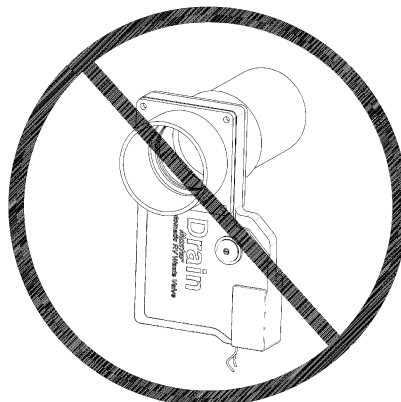

INCORRECT

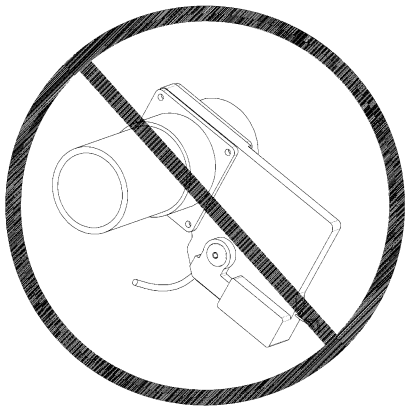

INCORRECT

OPERATION

Congratulations on the purchase of your new recreational vehicle. Your RV comes equipped with Drain Master electric waste valves. We are confident that our product will be a true benefit to your future RVing experience.

- Your Drain Master is extremely easy to use and requires little maintenance.
- Before you use your Drain Master, make sure you are ready to empty your waste, i.e. sewer hose is hooked up.
- When you are ready to dump your waste, simply push the switch up toward the word “open” and watch for discharge down the sewer hose. If your valve is equipped with the **magnetic switch (LED Light) your light will come on.
The Drain Master will open in 1-2 seconds, which means you don’t have to hold the switch in the open position for more than 2 seconds.
- To close your valve, simply push the rocker switch to the “close” position. Again, the valve will close in 1-2 seconds. If equipped with LED, the light will go out when the valve is completely closed.
- The switch is a momentary center return (which means, when you release the switch, it will automatically return to off).
- Never hold the switch in the open or closed position for more than 5 seconds.
- **IMPORTANT:** Should you ever lose power to your RV; you can open or close the valve manually. To do this use the provided 1/8” Allen wrench located on the back side of the valve. On either side of the Drain Master, you will see the words *Manual Override* on the upper center area. The words Open and Close with directional arrows provide directions in which you will turn the Allen head in the middle of this wording. Turn in the direction you need. There will be resistance as you are overriding a safety clutch. Turn until the shaft stops. The gate will fully open or close with about a turn and a half with the Allen wrench. When convenient, check and correct electrical problem. * (see attached picture, page 4)
- **NOTE:** *If your valve becomes sluggish, you may need to remove the valve and remove debris from the gate area. Change and lubricate the seals, (only the seals purchased from Drain Master Industries will work with this valve, Part #DM30-SB). Lubricate the seals with Dow Corning 111 only. We also have a valve maintenance kit available for purchase, reference part number DM30-VMK.*

****If your valve switch is not equipped with the LED switch version, an upgrade is available for purchase, part number #DM30-MSK. Please call the toll free number to verify your valve is upgradeable.**

Technical assistance available. Call toll free. Also visit www.drainmaster.com for troubleshooting guide.

Drain Master Manual Override

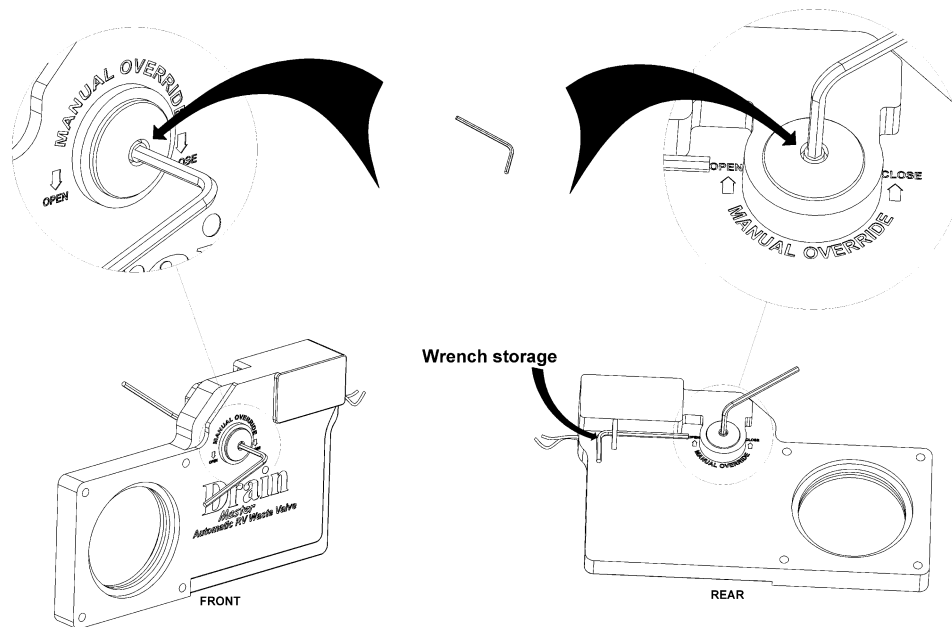

Determine which side of the Drain Master valve you are looking at (label is on the front). With a 1/8" allen wrench, turn the manual override in the appropriate direction (open or close) per the illustration above.

Note: The manual override was designed for use in emergency situations only (ie, loss of power, problem with valve). It is not meant to be used as a routine method of operating the valve.

NOTE

Product improvement is always very important to us. Recently we received enough input regarding the difficulty of using a blade screwdriver to operate the manual override, especially on 5th wheel trailers. We changed the override accordingly. The hex override allows this task to be done without actually seeing the valve. Do not use manual override for testing. The potential exists to mar or scratch the valve or damage the manual override. Use a power supply kit to open and close the valves. Contact Drain Master if you would like to obtain a power supply kit.

NOTE

If you flood test after installing the electric waste valve manifold, the valves need to be in the closed position. Then you need to first open the Waste Master Nozzle compartment, pull the Waste Master nozzle out and open the lever on the nozzle, prior to dumping the tank water.

NOTE

Unless you have specifically ordered a weatherproof switch for your valve, the switch is not weatherproof, and should be mounted in an area protected from moisture. Weatherproof switches are available for purchase.

Extend Retract Module Installation

The extend/retract module should be located in an area above the holding tanks and accessible for servicing. Refer to the production engineering drawing for proper location by coach model. The extend/retract module has an electrical plug that connects to the receiver wiring harness, as well as a ¼" quick connect tubing connector on top of the solenoid. In addition there is a 1.5" exhaust port that needs to be plumbed to one of the tank vents above the highest flood plain. Refer to engineering to be sure the location meets or exceeds RVIA specs. This module should be able to be removed without having to cut the exhaust lines or electrical wires. A threaded or rubber coupling after the exhaust port, close to the module, would work fine. The over-pressure relief valve (A) prevents the hose assembly from exceeding 2PSI. See illustration below.

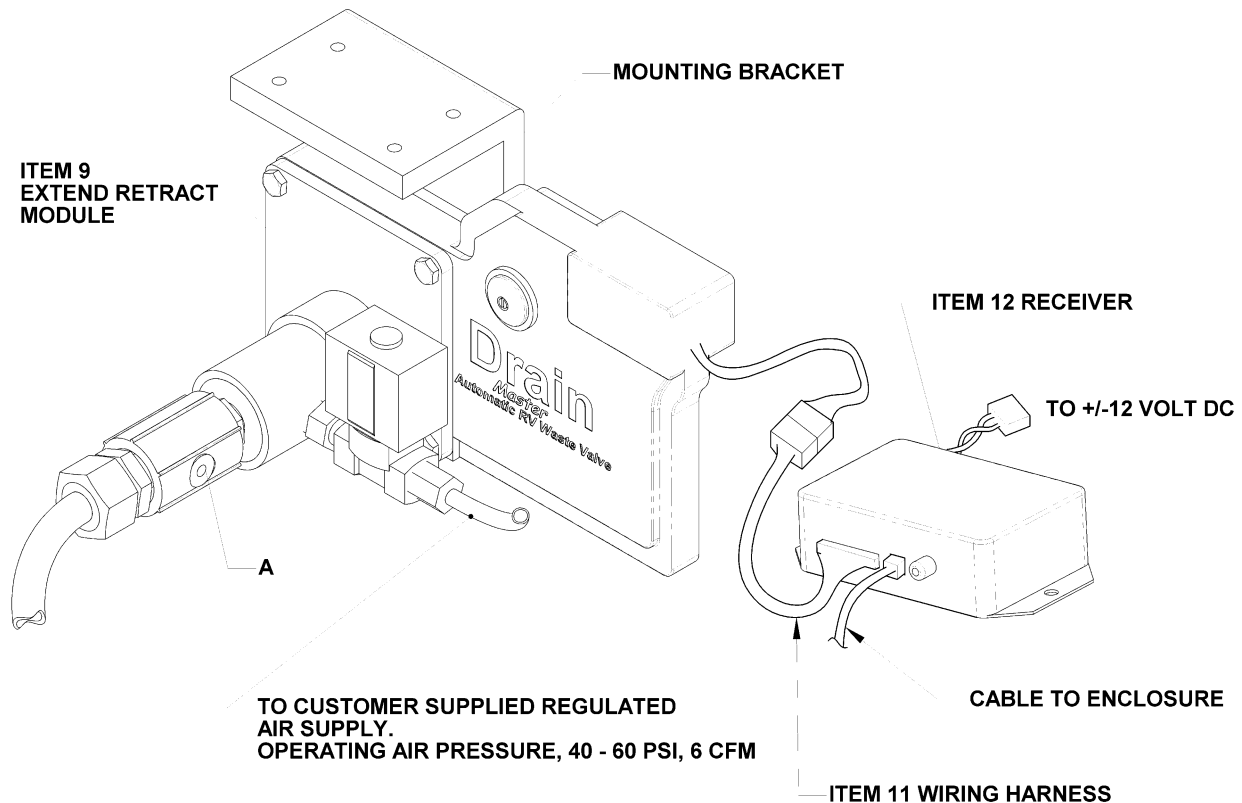

NOTE

IMPORTANT – Air Source must be connected to proper coach air supply tank.

Receiver Module Mounting

The receiver module should be located in an area accessible for servicing. It should be located away from moisture and electronic interference. Again refer to your production engineering drawings for location by coach model. The receiver has two things that need to be plugged into it: 1-, the antenna and 2-, the wire harness plug. Both the antenna plug and harness plug are located on the top of the receiver. A fused 12volt supply is required through the red (+) black (-) leads. When possible, mount receiver on driver's side of coach. The antenna should be free of interference for optimum reception. See illustration below.

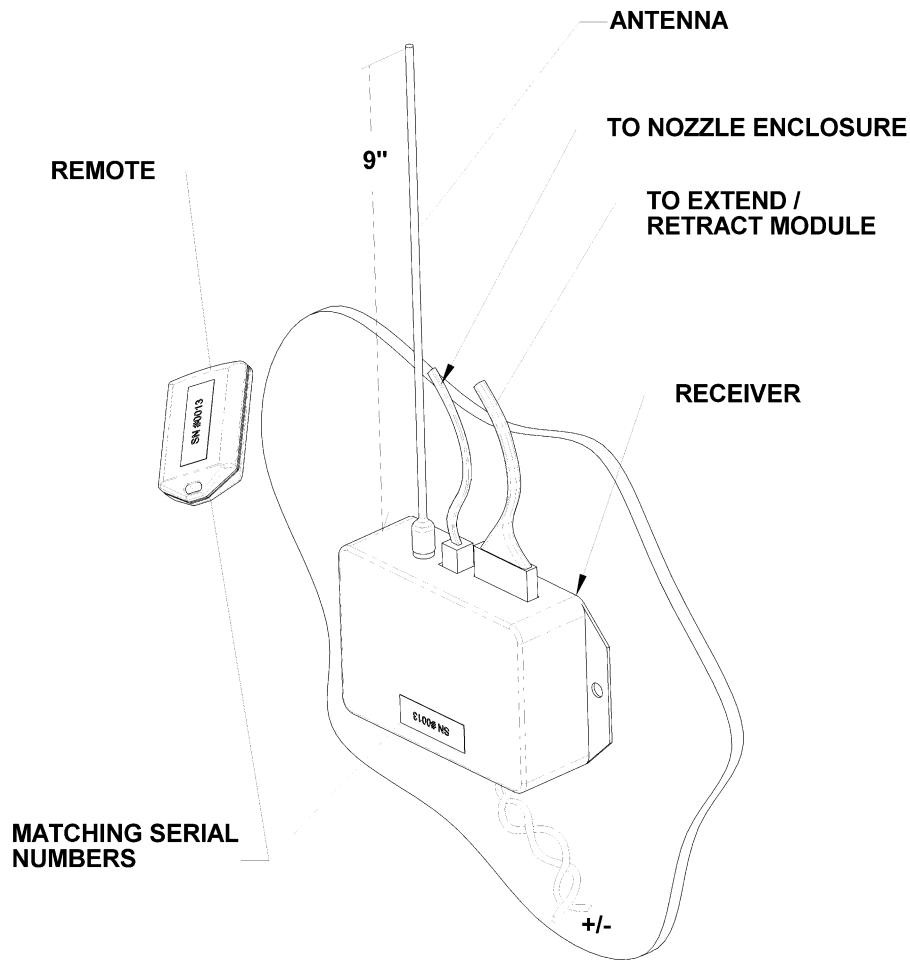

RECEIVER MOUNTING

Initial System Test

Valves and Switches

After installing the components, i.e. enclosure, nozzle, storage tube, extend retract module etc. a static water test is performed with valves closed. Extend hose and nozzle away from the coach. Insert nozzle into water outlet or lay on its side and open the gray lever on the nozzle. Cycle the Drain Master valves one at a time, the tanks will drain. Check to see that the LED light comes on when the valve is opened and off when the valve is closed. The valve should take about 1 second to open or close so you need to hold the switch in the desired position for at least 1 second. See operator instructions for more detail.

Receiver Module

To check the receiver function, the door needs to be open and you will need an air source, (shop or air tank) with minimum of 50 PSI on the regulator gauge. Open the enclosure door and using the key fob, push the extend button, #1. The nozzle will come out of the enclosure after a short delay. Take hold of the nozzle handle and continue to hold down the extend button (button 1 on left side of remote), The hose will continue to extend as long as you hold button 1 down or up to 19' away from the coach. If you continue to hold button 1 down after the hose is fully extended, a pressure relief valve located on the extend retract module will bleed off excess air.

To retract the hose, push button 2 on the remote and after a brief delay (1 second) the hose will begin to retract back into the enclosure. If you let go of button 2, the hose will stop retracting. Push again and it will retract again. If after the nozzle is back in the enclosure and you continue to hold button 2, you will eventually drain your air source with no damage to the system.

Operation

The basic operation of the Waste Master System is the same as noted in the initial system testing section under receiver module. The Waste Master Evacuation system makes hooking up the sewer hose to ground connections effortless and more sanitary for the user.

Extending the Hose and Nozzle

To extend the hose, remove the remote from its home location, open the enclosure door, push button 1 on the remote. The hose nozzle will come out of the enclosure, at which time you take the nozzle handle and as you continue to push button 1, the hose will extend out of the enclosure. If you are testing with water, put the nozzle into the sewer inlet and open the gray handle on the side of the nozzle. Go back to the coach service compartment located above the nozzle enclosure. Locate the Drain Master switches, push the black switch to open the black tank valve, and then push the gray switch to open the gray tank valve. When the water has finished running out of the hose, close both tank valves, (the red LED lights on the valve switch panel will go out confirming the valve is closed).

Flood Testing the Holding Tank System

After visual inspection of the holding tanks and associated plumbing, be sure the Drain Master electric waste valves are closed. Drain Master Industries can provide you with a portable valve tester so you can confirm the valves are working correctly, and are in fact closed and the LED light on the tester is off. Call our service department at 1-877-787-8833 if you do not have a tester available. Again, the tester is portable and very easy to use. See next page for test unit instructions.

Retracting the Hose and Nozzle

Return to the nozzle and close the gray handle. Remove the nozzle from the sewer inlet and push button 2 on the remote. As you hold the button down, the hose will begin to retract back into the enclosure. When closing the door, be sure to depress the spring prior to closing the door. It's that simple!

NOTE: Do not use the manual override to open or close the valves.

Valve Test Unit Instructions

- Turn unit on
- Plug valve into unit.
- Press button to open and close valve
- Check that the valve opens and closes smoothly in 1 second or less
- Check LED light. Off = gate closed On = gate open
- Turn unit off
- Charge weekly or as needed

The holding tanks can now be filled through the toilet for the black water and a sink or shower for the gray water. The tanks may remain full as long as necessary to adequately verify no leaks are present in the system.

NOTE: This procedure differs from the normal flood test method and it may be advantageous to add a clean out port in a convenient place in the gray water line to facilitate a faster fill.

If the coach wiring is not completed, and it is time to flood test and drain the holding tank, the tester MUST be used to open the valves. Do not use manual override.

If you have any questions regarding your current test methods and feel your method is appropriate and conforms to the above, please contact us prior to beginning the use of Drain Master electric valves. **1-877-787-8833 Toll Free.**

Calibrating Tank Monitors

(Tank Monitors not supplied with the Drain Master System) Use the manufacturer's standard procedure.

NOTE

Be sure to leave both valves closed while calibrating tank lever monitors. Leave the hose nozzle open during calibration and when emptying tanks.

NOTE

The hose is a transfer device – not a storage device. Do not open valves when nozzle is closed.

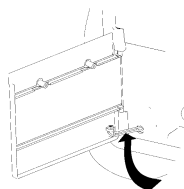

Depress spring prior to closing the door.

NOTE: To ensure maximum sewer hose life, please follow the following guidelines. After closing the nozzle lever and removing the nozzle from the sewer inlet, raise the nozzle so the sewer hose is not dragging on the ground, then retract the hose into the enclosure. Also if you are starting from the rear or front side of the coach, before retracting the hose, walk to the center of the enclosure so the hose is in direct line with the enclosure before retracting. This procedure lines up the hose so it does not rub on the enclosure as much.

What the customer will do

The customer will do exactly what you just did in the previous two headings only his/her tanks will be full of WASTE. They will clean their holding tanks as well. They will no longer mess with unsanitary fittings (which need a place to be stored) nor will they have to clean the sewer hose after dumping. They will be completely isolated from coming in contact with waste.

Receiver / Transmitter Information

RCR/KTXxxxB Remote Control System: Introduction: This product is used in miscellaneous applications requiring short-range remote control of on/off functions.

FCC ID: N6PKTX303: This device complies with Part 15 of the FCC Rules. Operation is subject to the following two conditions:

- (1) This device may not cause harmful interference and
- (2) This device must accept any interference received, including interference that may cause undesired operation.

The user is cautioned that changes or modifications not expressly approved by the party responsible for compliance could void the user's authority to operate this equipment.

Transmission Range: The transmission range of this unit depends upon the environment of the signal path, the type of receiver used and the type of receiver antenna used. Using Applied Wireless RCR receiver or RX module with an Applied Wireless decoder and a quarter wave vertical antenna, line-of-sight range of 300 feet is normal. The use of a dipole antenna will extend the range even further. When the RCR receiver is used with a quarter-wave antenna with ground plane, up to 1000 feet can be achieved. Non line-of-site applications can have significantly shorter transmission range.

Addressing: For security purposes, this transmitter is programmed to one of 1,024 different addresses. The receiver must be programmed to the same address as the transmitter. The receiver may come programmed to your transmitter from the factory. If not, you will need to have the receiver learn the transmitters ID.

Remote Control Programming (Note- Enclosure door must be open to program)

To program the receiver, remove the receiver antenna (to prevent the receiver from inadvertently learning an undesired transmitter), press the learn button on the receiver (the learn LED will light), and then press and hold any button on the transmitter until the LEARN light goes out. The transmitter must be within two feet of the receiver. When the learn button goes out, the receiver has finished the programming. Removal of the cover may be required to access the learn button and to observe the LEARN light.

The receiver may learn up to 4 different transmitters, each with different ID's. If a fifth transmitter is programmed, the first transmitter ID code that was programmed will be deleted and replaced with the new ID.

Momentary and Latched Operation: The RCR receiver comes from the factory in the MOMENTARY mode. In this mode, the output is activated only for as long as the key fob button is pressed.

If LATCHED operation is desired (in latched mode, the activated output stays activated until another button on the key fob is pressed), it will be necessary to move the internal shunt to the LATCHED position. Remove the cover on the RCR receiver for access.

FINAL QC

Testing valves

Open black first. Red LED should come on almost instantly. Hold "open" button down for 1 – 2 seconds. Valve will sound fast and not sound in stress (may require 2 people as the valves are on the passenger side of coach)

1. Open gray water valve. Check for LED light to come on. Follow same procedure for black water valve as described above.
2. Check switches for gray & black labels and that they are on the correct valves.
3. Check physical appearance is neat, switch plates are lined up and all 8 screws are tight. Be sure that there are no cracks on the switch plate.

Nozzle enclosure

1. Check to make sure keys are present.
2. Check exterior for scratches and proper placement of any beltline trim if applicable.
3. Open door and check to be sure that the Dutch door feature (latches etc.) work freely. Actuate door lock a few times to verify free operation. Check door latch to be sure it is not too weak or tight. Check cosmetics on both doors for any imperfections.
4. If remote key fob is mounted on inside of door, check to see that the Velcro is clean and aligns with key fob Velcro.

Extend Nozzle & Hose

1. Check two button remote for proper labeling; raised Waste Master Seal on front and serial number on back.
2. Push button #1 on remote and nozzle will exit the enclosure. Grasp handle on nozzle and continue to hold button #1 down. As hose extends, stop at approximately 5 feet from coach by letting go of button #1. After brief pause, push button #1 and walk all of the way (about 19 feet) from coach. Open and close nozzle handle checking for smoothness of travel and cosmetics of nozzle (clean with no blemishes). You will need air pressure to perform this test.

Troubleshooting

Waste Master

Symptom

- Hose will not extend or retract
- Hose nozzle swivel turns hard
- Nozzle leaks at swivel
- Hose retracts when button 1 or 2 is pressed
- Hose extends when button 1 or 2 is pressed
- Hose extends or retracts very quickly
- Hose extends or retracts very slowly.
- Transmitter does not work
- No power to switches
- No power to switches (cont)

Possible Cause(s)

- No 12VDC to receiver
- 12VDC to receiver polarity sensitive
- Air pressure (50PSI at regulator)
- Codes match on key fob, receiver
- Antenna in place
- Good cable connections
- System is open to atmosphere – tank valves or nozzle are open
- Key fob is not programmed to receiver
- No air
- New & stiff
- O ring seal
- Extend retract valve is stuck open
- Extend retract valve is stuck closed
- High air pressure. Pressure must be 50PSI at regulator
- Low air pressure. Pressure must be 50PSI at regulator
- No 12VDC to receiver
- -When you push button 1 or 2 do you get a green flashing light – If NO-
- Make sure enclosure door is open

Corrective Action

- Check power source
- Drain Master valve may be open
- Nozzle could be partially open
- Replace with end seal
- Adjust Pressure
- Adjust Pressure
- Check Power Source
Check Cable Connection
- Need to change out battery in transmitter (23AE 12V Battery)
- If door is open, check the phone line that is plugged into the receiver and other end behind enclosure
- Is manual switch on enclosure working? (Manual switch is black switch located on upper right hand of enclosure). If so, the above phone line is bad and needs to be replaced.
- Also, check to make sure round silver magnet on door is lining up with round white magnet on enclosure.

Drain Master

Symptom

- Valve won't open or close
- Valve opens or closes slow
- Valve won't close completely
- Valve is sluggish
- Valve leaks externally
- Motor continues to run
- Motor won't start, no sound
- Manual override spins, but gate does not open
- LED doesn't light when valve opens

Possible Causes

- No electrical power
- Faulty wiring
- Blown fuse
- Motor burnt out
- Faulty mag switch
- Door on enclosure is closed
- Valve in a bind
- Low voltage / amperage
- Defective motor
- Seals out of place
- Blockage at gate
- Seal rolled or pinched
- Excessive sludge build up in gate area
- Seal installed incorrectly
- Leaks at wires
- Leaks at manual override
- Switch sticks
- Switch defective
- Motor burnt out
- No power
- Broken gear
- LED burnt out (unlikely)
- Switch bad or wired incorrectly
- Bad connection on plugs

Corrective Action

- Check power source
- Check all connections
- Replace fuse
- Replace valve
- Check and repair as needed
- Open door
- Relieve stress on valve, install rubber coupling
- Check power source / wire size
- Replace valve
- Check seals
- Flush tank
- Replace seals
- Perform maintenance
- Replace seals
- Replace valve
- Replace valve
- Replace switch
- Replace switch
- Replace valve
- Correct power problem
- Replace valve
- Replace LED
- Too much amperage on switch ½ amps. max.
- Test for good connections

NOTE

If your LED does not go out, first check to see that the gate is completely closed. This can be done using the manual override. If light goes out, you could have a blockage in the gate area. If light does not go out, try putting a magnet on the switch that is mounted on the valve. If light does not go out, the switch is shorted and will require replacement. If the light does go out when magnet is placed on the switch, the switch is out of position, or there is blockage preventing the gate from closing completely. Please call Drain Master for a template and replacement switch.

Replacing the Magnetic Switch

1. Remove the defective switch by sliding a small screwdriver blade under a corner of the switch and **gently** pry it up. The switch has been glued to the valve and it may be necessary to break the switch. Clean the area where the old switch was removed, making sure it is smooth.
2. Place the switch in the area the old switch was removed from. Be sure to close the valve fully.
3. As you move the switch, the LED light should come on and go off. NOTE: *The switch is "normally on" so it should stay lit until it comes in contact with the internal magnet at which time the LED light will go out.*
4. Attach switch to valve using a drop of ABS glue.
5. Run the wires through the hole in the bracket under the motor housing. Attach leads to the wires that the old switch was connected to.

Care and Installation

To insure Drain Master is installed correctly, a couple of differences exist between the manual style valves and the new Drain Master. Electric valves differ from manual valves in one very important way; the motor has a specific torque output, which is strong enough to open a holding tank, which is 10 feet in height. The manual valve relies on the person to provide the torque and that varies person to person. Installation becomes much more important because any undue stress created by over tightening the flange bolts or putting the associated plumbing in a bind requires more torque than the motor creates. When this happens the Drain Master will sound like it is running but won't open because the clutch inside starts to slip (instead of stripping the gears). Until this undue stress is relieved either by loosening the bolts or taking the stress off the flanges, the valve will not function as intended.

By purchasing the Drain Master with the flanges attached to the valve, the seal is in the correct position and the flange bolts are torqued to the proper setting. (20"lbs.) This reduces installation time on the production floor.

The following list will help in obtaining a professional installation:

1. Valves and assemblies are tested for proper operation and for leaks before leaving our facility.
2. Valves should be kept in their individual packages until installation.
3. The 4 mounting bolts are torqued to 20 inch pounds.
4. Always follow all applicable codes and regulations.
5. When piping, extreme care must be taken not to put the valve in a bind or stressed position. This can cause undue pressure on plastic parts.
6. The valve should not support the piping. The valve should be in a relaxed state.
7. Care must be taken to keep the valve in a relaxed position when strapping or supporting the piping.
8. Do not install Drain Master against side walls-struts-cross members. This will cause vibration, along with difficulty, should servicing be needed.
9. The motor is always installed above the centerline of the pipe. The valve can be installed vertically.
10. Either side of the valve can be used as the pressure side (5 PSI Max).
11. Never flood test the system with the valve open.
12. The end user must easily access the manual override. The manual override must always be accessible and visible to the end user.
13. Tanks should be clean of all debris.

14. The valve should be easily accessible for service.
 15. Install valve as close as possible to tank. Installing the valve at the tank opening reduces the potential for tank blockages and keeps the valve away from damage.
 16. When gluing assemblies in place, care must be taken to not allow glue to come in contact with the gate, or valve body.
 17. Keep excess glue from collecting on valves and mounting bolts.
 18. All piping should be 3". Avoid the use of reducers. 3" valves on the gray tank speed the dumping time by 2.53 times (over 1.5" Valve) and helps keep tank cleaner.
 19. Always test valve operation before installation. Simply cycle a couple of times using a 12vdc battery. Reverse the red and white wires on the battery posts to open and close. Be careful to keep fingers away from the gate. IT WILL HURT YOU!! **Drain Master can supply a test transformer for on-line testing.**
 20. Never use the manual override for testing.
 21. The only recommended lubricant for the seals is Dow Corning 111. Call if you need some.
 22. Insure good electrical connections.
 23. Never use wire smaller than 20 gauge. Heavier gauge wire should be used for long runs to compensate for any voltage drop.
 24. Valve runs on 12 Volts DC only.
 25. As with all DC battery operated devices, best performance is achieved with a fully charged battery or the use of a generator. Discharged batteries will cause the valve to be sluggish or even fail to operate.
 26. Switches are not waterproof or watertight. Switches must be installed in a dry location.
 27. If using your own switch, momentary contacts must be used.
- ❑ Fuse: Drain Master must be properly fused. When using blade type automotive fuses, a 5.0 Amp fuse must be used. If glass type fuse is used, MDL-5 or equal must be used.
 - ❑ Re: valves with Magnetic Switches- Because of the high number and proximity to equipment capable of generating stray current surges, it is highly recommended that we review a few installation guidelines to help prevent damage to the magnetic switch used to monitor the valve gate position.
 - Wire runs from the rear to the front of the vehicle should be kept as short and as straight as possible.
 - Care should be taken to route connecting wire away from existing wiring and away from pump, blower or inductive type motors and spark plugs.
 - Persistent problems may require a shielded and grounded wire run from the back to the front of the vehicle.
 - ❑ **Failure to follow the above procedures may void any warranty claims.**

A Word about the Sewer Hose

Your sewer hose is the most durable hose on the market today and will give you many years of trouble free service with proper care.

Repair Procedure

Should the hose incur damage, a pinhole, cut or burn, etc it can be repaired.

1. First locate the source of the problem and mark it with a grease pencil, marker or tape.
2. Remove the hose from the coach. See details removing the Hose for Service.
3. Stretch the hose out in the area of the problem.
4. With a sharp knife cut out the damaged area and use a pair of wire cutters to clip the wire.
5. Remove the extra brown plastic around the wire leaving the white plastic over the wire. This cleans up both ends of the hose.
6. Lay the hose out on a flat surface with the two cut ends facing each other.
7. Push the two ends together and turn them in opposite directions toward each other. One hose will start to turn into the other.
8. The hose going inside the other now needs to have some silicon-based lubricant sprayed on it so it will be easier to turn the hose.
9. Continue to turn the hose into each other until it stops turning. It will go in about 3 turns. You are done; the hose won't leak or come apart!

Removing the Hose Assembly for Servicing

Locate the end of the hose opposite the nozzle. It will be located on the passenger side of the coach directly opposite the nozzle enclosure on the driver's side of the RV. A white sleeve will be over the actual fittings. Slide it back over the storage tube exposing the 3" fittings. Using a strap wrench unscrew the male fitting which is attached to the hose. When undone go to the drivers side of the coach, open the enclosure door and pull the nozzle and hose completely out of the compartment.

Installing the Hose Assembly

Insert the opposite end of the hose assembly, the male 3" fitting, into the enclosure and continue to push the hose until it reaches the female fitting on the passenger side of the RV. Coat the male threads with pipe dope, and then screw the fittings together until tight and leak free.

For additional information or questions before beginning please call our toll free # 877 787 8833.

Field Changing Of Waste Master Nozzle

Materials:

Silicone caulking – not included

Tie wraps – included

Nozzle – included

Remove existing hose from the nozzle by cutting the hose approximately 2” from the end – this will clear the existing fitting (the hose is made from polypropylene; you will need to use a new blade in your utility knife for best results). The best way to make the cut is to place the blade next to one of the wires and cut around the hose following the wire. Once you have cut around the wire, you will have to cut the wire with a pair of wire cutters. Please note: Tin snips will not make this cut!

Extend the hose approximately 4” from the end. Using silicone caulk – approximately ¼” thick bead on the inside of the hose following the helical wire until one complete revolution is made.

Take the new nozzle and move the handle to the “open” position.

Insert barbed fitting completely into the extended hose.

Install the tie wrap around the hose and barbed fitting. The arch at the head of the tie wrap must straddle a wire on the hose. Pull the tie wrap tight, and cut off the excess.

Allow the silicone caulk to “cure” following instructions on the container, typically 24 hours.

Warranty Information

For customer service, technical assistance or to obtain a return authorization number, call 1 (877) 787-8833. Fax: (831) 636-3759 E-mail: [OEMSERVICE@DRAINMASTER.COM](mailto: OEMSERVICE@DRAINMASTER.COM) Address for returns: Drain Master Industries, O.E. Customer Service Dept., 1591 Shelton Drive, Hollister, CA 95023

Information about Returns

The Drain Master Industries commitment is to have satisfied customers. Occasionally it may be necessary to return parts to PFI. This policy covers most return situations. The conditions are designed to be fair to our customers and provide internal cost control so we can maintain our value pricing.

If we make a mistake with your order, we apologize for the inconvenience. Please call us, and we will ship the correct items immediately. PFI will provide merchandise credit upon receipt of the returned material.

If you return unused product within 30 days, there is a 25% inspection and restocking charge. PFI will credit your account provided that the returned items are in sellable condition.

No products will be accepted for return after 31 days from date of invoice. These conditions apply to items returned in new condition, original packaging and undamaged.

Special orders and dedicated inventory:

Orders for products which are specially fabricated to the Purchasers specifications or request may not be modified, cancelled or returned by the Purchaser. The Purchaser covenants to indemnify PFI from any loss arising from such action by the Purchaser. Dedicated inventory constitutes product which PFI keeps on hand to service the Purchaser. This includes products built to the Purchasers specifications and all parts that PFI stocks to build such products. Purchaser shall always be responsible for timely relieving Seller of all such inventory in accordance with the agreed upon schedule.

Warranty

Returns involving warranty claims

The time period for the Waste Master warranty is equivalent to the coach manufacturer's limited warranty, (not the chassis warranty) and is guaranteed to be free of mechanical defects in material and workmanship

During the warranty period PFI will replace the product only if deemed defective due to mechanical defect in material and workmanship, which will be your exclusive remedy under this warranty. Drain Master Ind. shall not be liable for any special, incidental, indirect or consequential damages whatsoever (including, without limitation, labor or installation charges, damages for loss of business profits, business interruption or any other pecuniary loss) arising out of the use of or inability to use the product.

- Proper installation procedures **must** be followed for the warranty to be valid.
- The faulty product must be returned, freight pre paid, to PFI for inspection before replacement product will be sent to you.
- If your warranty dept. is separate from production / manufacturing, you will need to purchase warranty replacement product in advance.
- You must call for a **Return Authorization Number** before sending product back to PFI.
- The warranty does not cover inbound freight. It does cover outbound freight of the replacement product.