



P.O. Box 2316
Hollister CA 95024-2316

Waste Master™ (WM-1) Waste Evacuation System

Installation / Operation Manual

The new Waste Master System you are about to install is the latest in customer convenience.

This system makes emptying the holding tanks as simple as putting gas in the car.

No more mess or contact with waste from the tanks.

And...it's environmentally friendly.

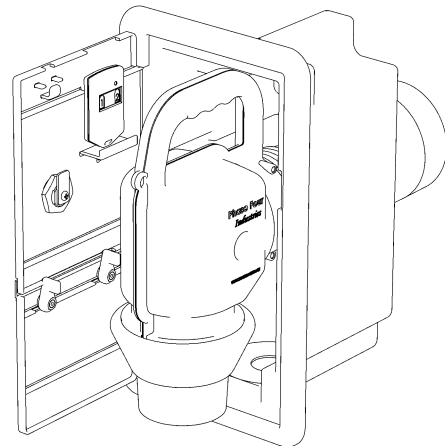
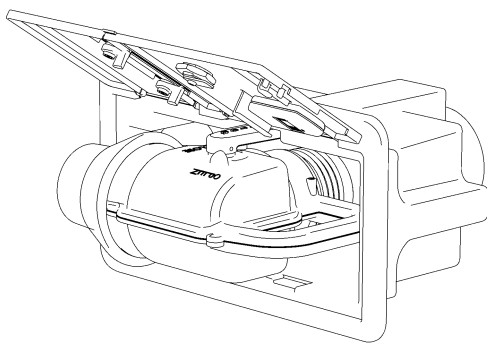

Coach Serial # _____

Package Serial # _____

Notice

The information in this guide is subject to change without notice. Parts illustrated are representative and are subject to change.

Drain Master shall not be liable for technical or editorial errors or omissions nor for incidental or consequential damages resulting from the furnishing, performance, or use of this material.

This guide contains information protected by copyright. No part of this guide may be photocopied, reproduced, transmitted, or stored in any form without prior written consent from Drain Master.

© Copyright 2004-2010 Drain Master LLC. All rights reserved. Printed in the U.S.A.

Waste Master™, Drain Master™ are trademarks of Drain Master LLC.

Product names mentioned herein may be trademarks and/or registered trademarks of their respective companies.

Table of Contents

Introduction	4
Product Overview	4
Listings	4
How the Waste Master System Works.....	5
Operation of the WM1 Waste Master System for The RV Owner	5
Installation.....	7
Components Supplied With Kit.....	7
System Diagrams.....	8
Wiring Diagram.....	8
System Diagram.....	9
Installing the enclosure and storage tube	9
Installing the Holding Tank Valves	10
Wiring.....	13
Valves and Switches	13
Initial System Testing.....	13
Valves and Switches	13
Operation	13
Extending the Hose and Nozzle	13
Flood Testing The Holding Tank System.....	13
Test Unit Instructions.....	13
Calibrating Tank Monitors.....	14
Retracting the Hose and Nozzle	14
What the Customer will do	14
Final QC.....	14
Test both gray and black waste valves	14
Nozzle enclosure	14
Extend Nozzle & Hose	14
Troubleshooting in Production – Waste Master	15
Troubleshooting in Production – Drain Master	15
Replacing the Magnetic Switch	16
Care and Installation	16
OPERATION.....	18
A Word About the Sewer Hose	19
Field Changing Of Waste Master Nozzle	20
OEM Warranty	21
Information About Returns.....	21
Warranty.....	21

Introduction

Product Overview

Waste Master brings a whole new era to the RV Industry! In the past emptying holding tanks was the “least desirable task” in the life of an RVer. Not any more! Now emptying holding tanks is as simple as putting gas in the family car!

No more getting the hose out, adding fittings (that don't have handles), removing and cleaning the hose before storing it away.

Waste Master is totally sanitary because the user is not exposed to waste at any time during the waste evacuation process.

Waste Master comes with many features and upgrades. The sewer hose and nozzle extend a full 16-19' from the RV! The nozzle features a sanitary handle and a compression donut to insure no sewer gasses escape and the swivel on the nozzle allows the nozzle to be laid on its side when needing an extension hose added to the nozzle. Our Sewer Supreme 18mil (Black) standard sewer hose is superior to industry standard vinyl hoses. For full time use we offer the optional Sewer Master 20mil polypropylene hose.

We are constantly looking for ways to improve our products and welcome your thoughts.

Listings

ANSI A119.2 LISTED



Operation of the WM1 Waste Master System for the RV Owner

To operate the Waste Master System you;

1. Unlock and open Waste Master compartment door.
2. Pull the nozzle from the compartment and walk to the sewer inlet, up to approx. 16-19 feet from the RV.
3. Insert the nozzle tip into the sewer inlet.
4. Open the lever (gray handle) on the side of the nozzle. Handle up indicates open and down is closed. Open and closed are clearly marked on the nozzle.
5. That's it! You are now ready to empty your holding tanks.
6. In the services compartment you will locate the switches for the Drain Master electric waste valves.
7. Push the black switch up to open the valve. NOTE; The valve will open in about 1 second, very fast, so release the button. If your valve is equipped with an optional LED light on the switch the light will illuminate when the valve is open. The switch works like the power window button in your car and will stop when you release the button. The valves have an override clutch so you cannot hurt the system by holding it down longer than 2 seconds; however it can shorten the life of the clutch or blow a fuse. Rule of thumb - Push and hold the button and count to 2, then release. Do this when opening or closing the valves.
8. Flush the black tank, as you normally would, then close the black valve. (if equipped with optional LED light, the light will go off when the valve is closed completely)
9. Open the gray valve. When the tank is empty, flush the tank (if equipped with this feature).
10. When done, close the gray valve. (if equipped with LED light, the light will go off when the valve is closed completely)
11. Now the fun part! Remember how you had to remove the hose and clean it? NO MORE.
12. Simply close the lever (gray handle) on the side of the nozzle; lift the nozzle from the inlet using the handle.
13. Holding the nozzle, walk back to the RV. Lay nozzle on ground, grasp hose near the enclosure and begin to collapse the hose and push it back into the storage tube. Close the door and you are done.
NOTE: Remember to depress the spring before closing the door!

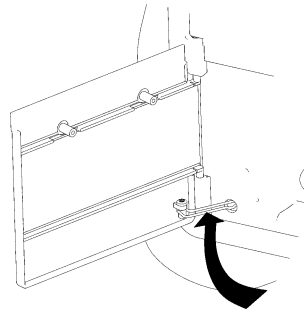

Remember to depress the spring when closing the door!

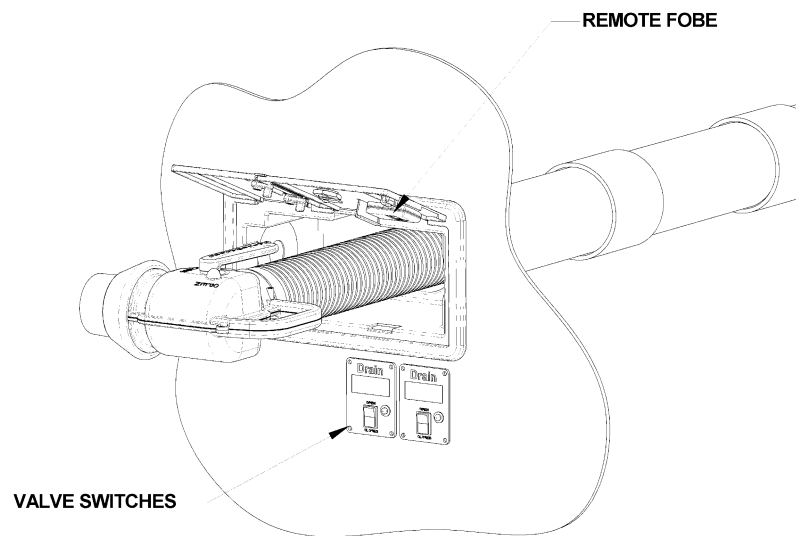
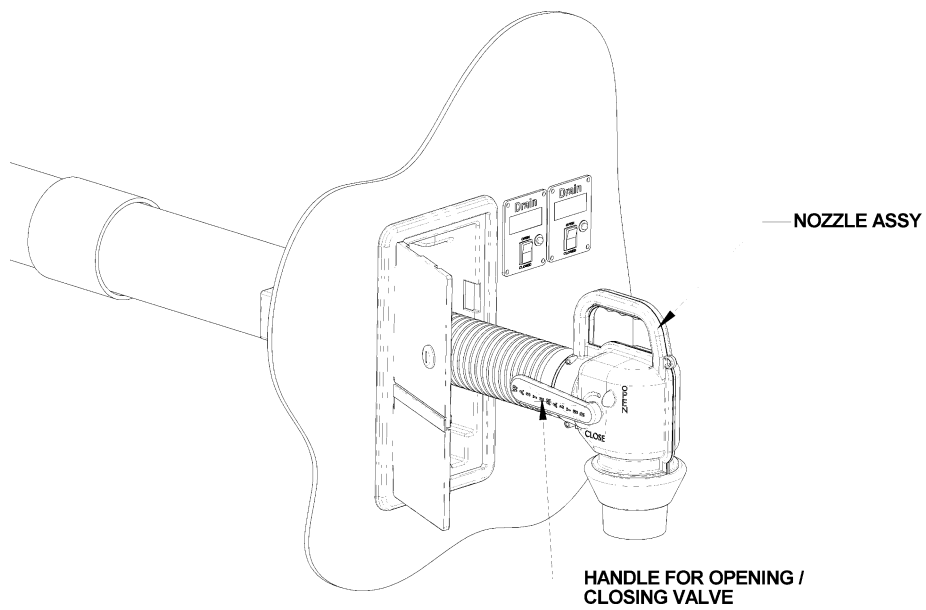

Installation

Parts List Supplied With Kit

1. Waste Master Enclosure Assy, Qty 1
Enclosure Keys Qty 2
Waste Master Door / Frame Assy w/o magnet Qty 1

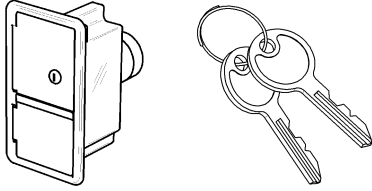

2. Nozzle/Hose Assembly
Sewer Supreme Hose (Standard)
Sewer Master Hose (Optional Upgrade)

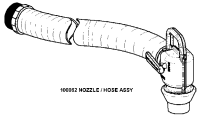

3. Storage Tube 4", Qty 2 – 37.5" ea (if equipped)

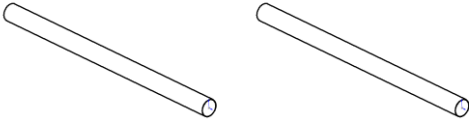

4. 4" Storage Tube Coupling, Qty 1 (if equipped)
NOTE INTERNAL RIB FEATURE



5. Drain Master Electric Valve assemblies, Qty 2
Includes valve flanges, either male or female, Qty 4

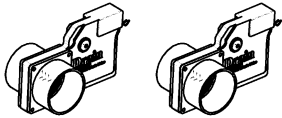

6. Drain Master Switches / mounting screws and labels, Qty 2
NON LED Operating Switches (Standard)
LED Operating Switches (Optional Upgrade)

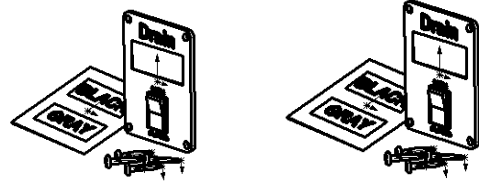

7. OEM Installation/Operation Manual on CD, Qty 1

NOTE

Immediately contact Drain Master 877-787-8833 if any parts are missing or damaged

System Diagrams

Wiring Diagram

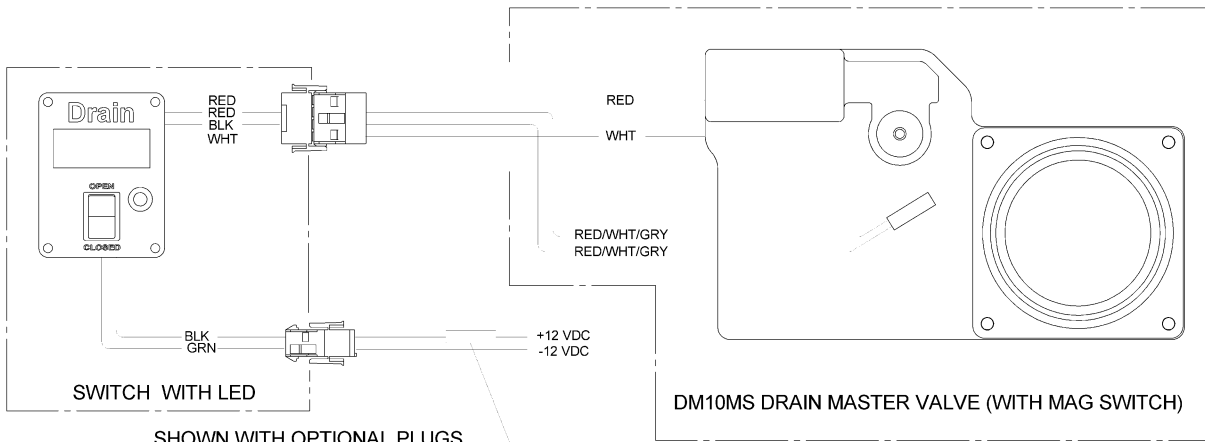
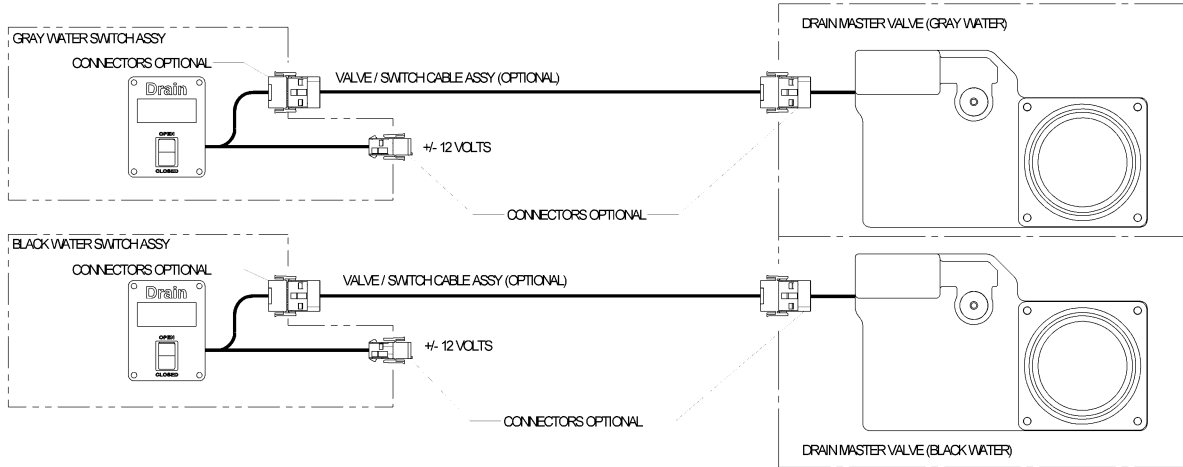
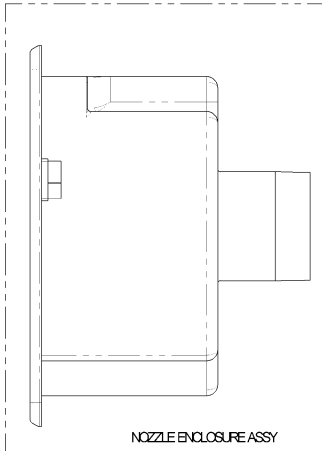

GLASS TYPE FUSE MDL-5 OR
AUTOMOTIVE BLADE TYPE 5.0 AMP

NOTE

Each valve must be fused separately for proper operation.

Mechanical Diagram

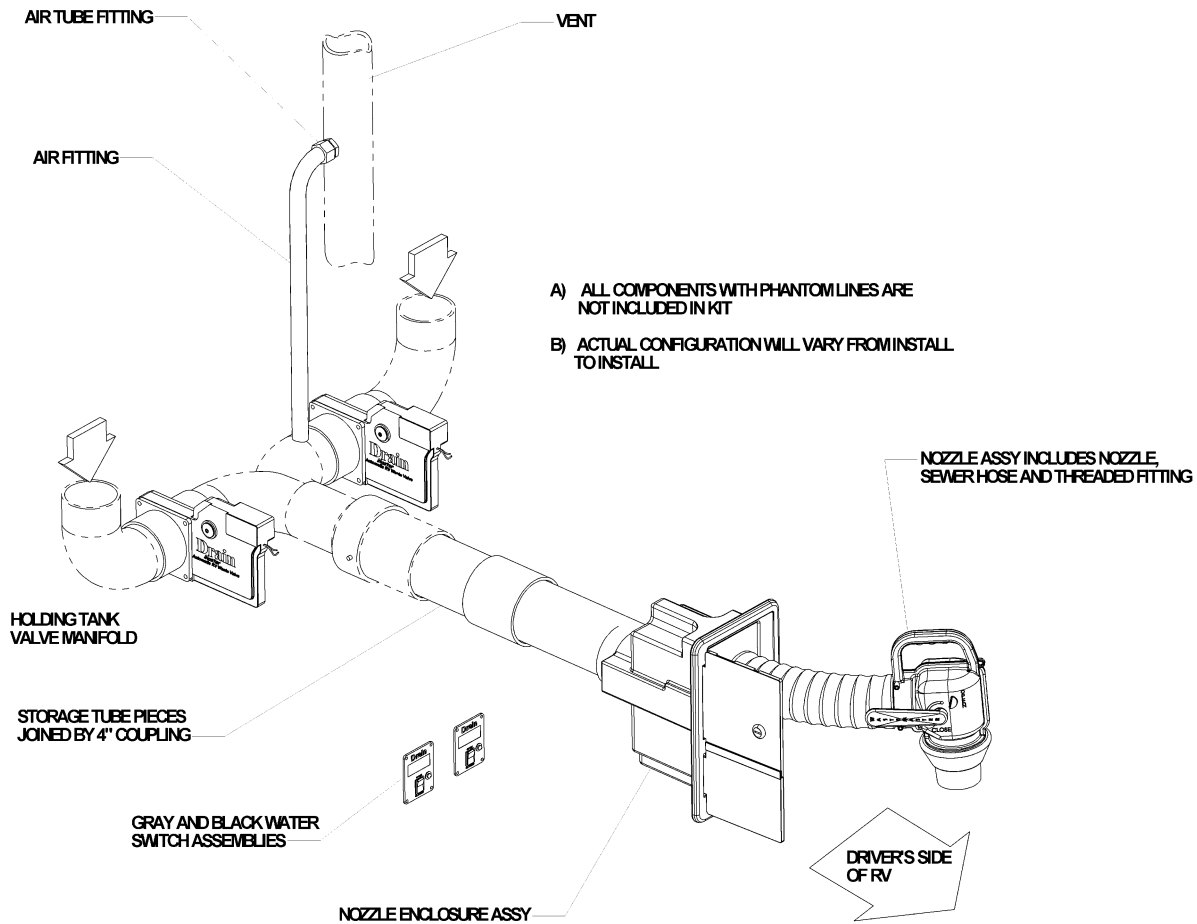

Installing the enclosure and storage tube

Refer to the production engineering drawing for the proper placement of the two storage tubes and enclosure. The storage tube arrives in two parts. The installation kit contains a 4" coupling, which is used to join the two 4" tubes together using all-purpose glue. Glue the tubes together with the coupling, and then slide the storage tube into place, as shown on the illustration. Next insert the enclosure in the 4" storage tube on the driver's side of the coach and push together firmly. **DO NOT GLUE** the storage tube and enclosure together. Do not secure the enclosure to the coach frame at this time, as the dress panels will need to be fitted at a later time. When the enclosure is mounted, be sure to provide a flat surface to mount to. Irregularities may result in inadequate attachment of the frame / door assembly. The storage tube (two 37.5" tubes together) needs support other than the attachment at the enclosure. Also, allow about 2.5" of space between the end of the storage tube and the 3" female coupling that the sewer hose threads into. This is for service access to the sewer hose. See Illustrations next page.

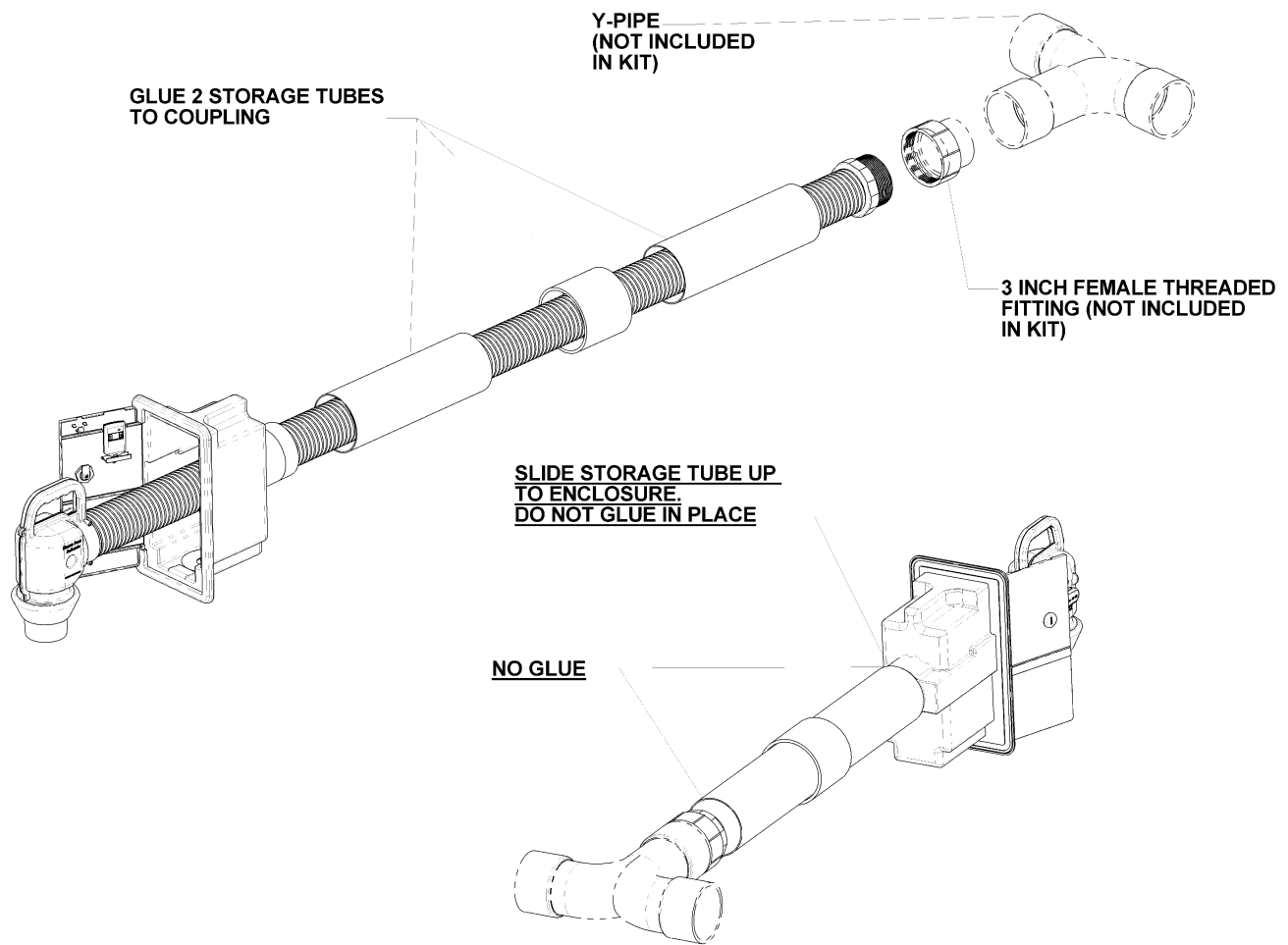

Installing the Holding Tank Valves

Refer to the production engineering drawing for proper location and configuration. The valves come with the hub and or spigot flanges installed. Do not remove these parts as they have been tested at the factory to insure they perform properly. If you need different configurations, please let us know and we will take care of it for you. If valves equipped with electrical plugs (option), an installation is a simple matter of Plug n Play.

You will need a 3" double 90 to join the two valves together. The valves are installed in the tanks either directly or with an extension piece (refer to the production engineering drawings for detail) The outlet of the double 90 gets a 3" male slip to 3" NPT female fitting glued in place. Refer to the illustrations on next page for proper valve orientation.

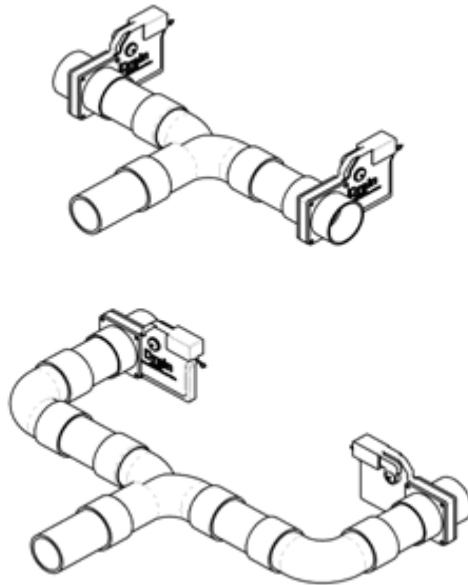

Acceptable Manifold Configurations

NOTE: It is recommended the valve manifold be sub assembled prior to installation. If the manifold is built on the coach, there is a chance the manifold will vary coach to coach, resulting in the hose nozzle not resting in the enclosure properly.

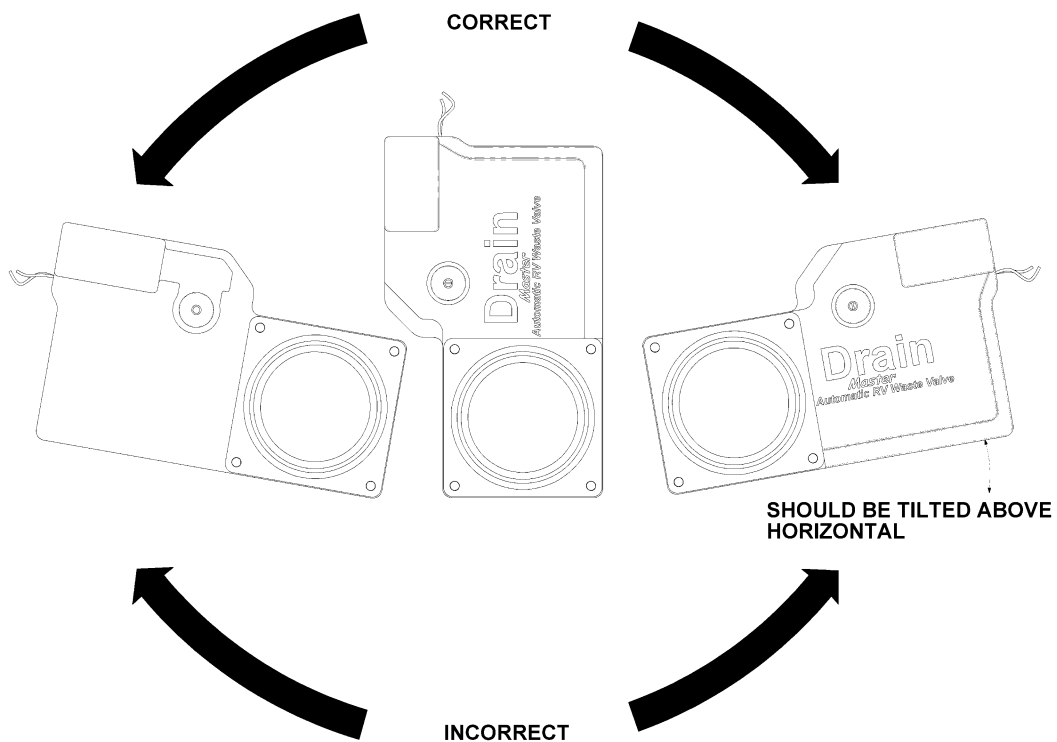

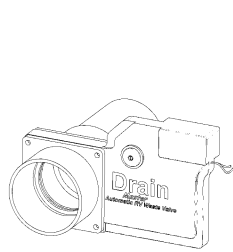

CORRECT

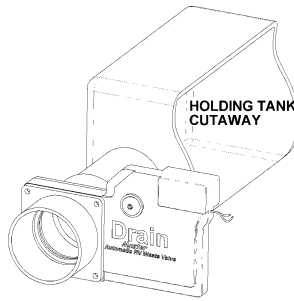

CORRECT

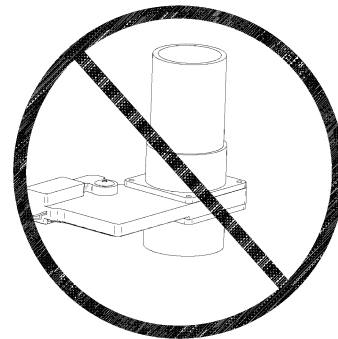

INCORRECT

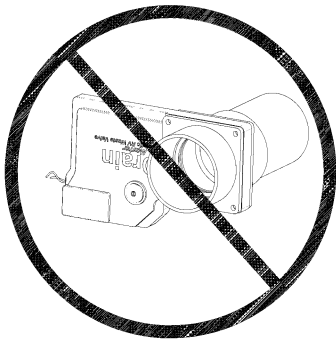

INCORRECT



INCORRECT

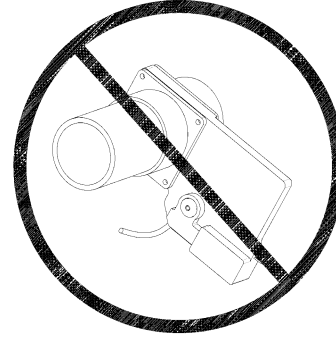

INCORRECT

Drain Master Manual Override

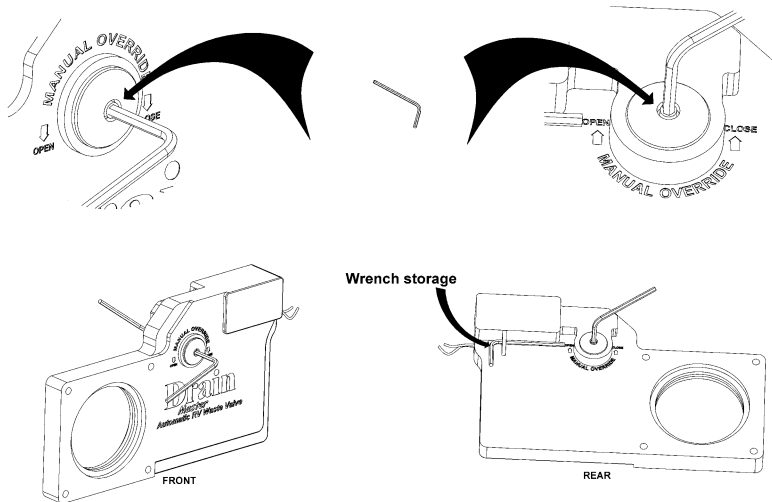

Determine which side of the Drain Master valve you are looking at (label is on the front). With a 1/8" allen wrench, turn the manual override in the appropriate direction (open or close) per the illustration above.

Note: The manual override was designed for use in emergency situations only (ie, loss of power, problem with valve). It is not meant to be used as a routine method of operating the valve.

NOTE: Product improvement is always very important to us. Recently we received enough input regarding the difficulty of using a blade screwdriver to operate the manual override, especially on 5th wheel trailers. We changed the override accordingly. The hex override allows this task to be done without actually seeing the valve. Do not use manual override for testing. The potential exists to mar or scratch the valve or damage the manual override. Use a power supply kit to open and close the valves. Contact Drain Master if you would like to obtain a power supply kit.

NOTE: If you flood test after installing the electric waste valve manifold, you first need to open the Waste Master Nozzle compartment, pull the Waste Master nozzle out and open the lever on the nozzle, prior to dumping the tank water.

Wiring

Valves and Switches

If equipped with this option, your Drain Master valves and switches have been pre wired using Mate-N-Loc style plugs and need only to be plugged into each other (sometimes through a corresponding harness). See "Wiring Diagram" under "System Diagrams" (page 8)

Initial System Testing

Valves and Switches

After installing the components, i.e. enclosure, nozzle, storage tube, etc. a static water test is performed with valves closed. Extend hose and nozzle away from the coach and insert nozzle into water outlet and open the lever on the nozzle. Cycle the Drain Master valves one at a time. Check to see that the LED light, if equipped, comes on when the valve is opened and off when the valve is closed. The valve should take about 1 second to open or close so you need to hold the switch in the desired position for at least 1 second. See operator instructions for more detail. Each tank will drain.

Operation

Extending the Hose and Nozzle

Open the enclosure door. To extend the hose simply pull the nozzle out of the compartment and walk to the sewer inlet. If you are testing with water, put the nozzle into the sewer inlet and open the gray handle on the side of the nozzle. Go back to the RV service compartment located above the nozzle enclosure. Locate the Drain Master switches, push the black switch to open the black tank valve, and then push the gray switch to open the gray tank valve. When the water has finished running out of the hose, close both tank valves, (the red LED lights, if equipped, on the valve switch panel will go out confirming the valve is closed).

Flood Testing the Holding Tank System

After visual inspection of the holding tanks and associated plumbing be sure the Drain Master electric waste valves are closed. Drain Master Industries can provide you with a portable valve tester so you can confirm the valves are working correctly, and are in fact closed and the LED light on the tester is off. Call our service department at 1-877-787-8833 if you do not have a tester available. The tester is portable and very easy to use. See below for test unit instructions.

Test Unit Instructions

Turn unit on

- Plug valve into unit.
- Press button to open and close valve
- Check that valve opens & closes smoothly in 1 second or less
- Check LED light, if equipped. Off = Gate closed On = Gate open
- Turn unit off
- Charge weekly or as needed

The holding tanks can now be filled through the toilet for the black water and a sink or shower for the gray water. The tanks may remain full as long as necessary to adequately verify no leaks in the system are present.

NOTE: This procedure differs from the normal flood test method and it may be advantageous to add a clean out port in a convenient place in the gray water line to facilitate a faster fill.

If the coach wiring is not completed, and it is time to flood test and drain the holding tank, the tester MUST be used to open the valves.

If you have any questions regarding your current test methods and feel your method is appropriate and conforms to the above, please contact us prior to beginning the use of Drain Master electric valves. **1-877-787-8833 Toll Free.**

Calibrating Tank Monitors

(Not supplied with the system) Use the manufacturer's standard procedure.

NOTE: Be sure to leave both valves closed while calibrating tank lever monitors. Leave hose nozzle open during calibration and when emptying tanks. **IMPORTANT:** **NOTE:** The hose is a transfer device – not a storage device. Do not open valves when nozzle lever is closed.

Retracting the Hose and Nozzle

Return to the nozzle and close the gray handle. Remove the nozzle from the sewer inlet and walk back to the coach. Lay the nozzle down and take hold of the hose near the enclosure and collapse the hose while pushing it back into the storage tube.

What the Customer will do

The customer will do exactly what you just did in the previous two headings only his/her tanks will be full of WASTE. They will clean their holding tanks as well. They will no longer mess with unsanitary fittings (which need a place to be stored) nor will they have to clean the sewer hose after dumping. They will be completely isolated from coming in contact with waste.

Final QC

Test both gray and black waste valves

1. Open black first. Red LED, if equipped, should come on almost instantly. Hold "open" button down for 1 – 2 seconds. Valve will sound fast and not sound in stress (may require 2 people as the valves are on the passenger side of coach).
2. Open gray water valve. Check for LED light, if equipped, to come on. Follow same procedure as for black water valve as described above.
3. Check switches for gray & black labels and that they are on the correct valves.
4. Check physical appearance is neat, switch plates are lined up & all 8 screws are tight. Be sure that there are no cracks on the switch plate.

Nozzle enclosure

1. Check to make sure keys are present.
2. Check exterior for scratches and proper placement of any beltline trim if applicable.
3. Open door and check to be sure that the Dutch door feature (latches etc.) work freely. Actuate door lock a few times to verify free operation. Check door latch to be sure it is not too weak or tight. Check cosmetics of both doors for any imperfections.

Extend Nozzle & Hose

1. Open enclosure door and remove nozzle. Continue to pull hose until it is fully extended (approx 16-19 feet). Check hose for cleanliness on the outside as well as any damage that may have occurred during installation. Clean and insert hose back into the storage tube.

Troubleshooting in Production – Waste Master

Symptom

- Hose nozzle swivel turns hard
- Nozzle leaks at swivel

Possible Cause(s)

- New & stiff
- Not greased properly

Corrective Action

Troubleshooting in Production – Drain Master

Symptom

- Valve won't open or close
- Valve opens or closes slow
- Valve won't close completely
- Valve is sluggish
- Valve leaks externally
- Motor continues to run
- Motor won't start, no sound
- Manual override spins, but gate does not open
- LED doesn't light when valve opens (optional feature)

Possible Causes

- No electrical power
- Faulty wiring
- Blown fuse
- Motor burnt out
- Excessive glue on gate
- Valve in a bind
- Low voltage / amperage
- Defective motor
- Seals out of place
- Blockage at gate
- Seal rolled or pinched
- Excessive sludge build up in gate area
- Seal installed incorrectly
- Leaks at wires
- Leaks at manual override
- Switch sticks
- Switch defective
- Motor burnt out
- No power
- Broken gear
- LED burnt out (unlikely)
- Switch bad or wired incorrectly

Corrective Action

- Check power source
- Check all connections
- Replace fuse
- Replace valve
- Relieve stress on valve, install rubber coupling
- Check power source / wire size
- Replace valve
- Check seals
- Flush tank
- Replace seals
- Perform maintenance
- Replace seals
- Replace valve
- Replace valve
- Replace switch
- Replace switch
- Replace valve
- Correct power problem
- Replace valve
- Replace LED
- Too much amperage on switch ½ amps. Max.

NOTE: If your LED (if equipped) does not go out, first check to see that the gate is completely closed. This can be done using the manual override. If light goes out, you could have a blockage in the gate area. If light does not go out, try putting a magnet on the switch that is mounted on the valve. If light does not go out, the switch is shorted and will require replacement. If light does go out, when magnet is placed on the switch, the switch is out of position. Please call for a template and replacement switch.

Replacing the Magnetic Switch

1. Remove the defective switch by sliding a small screwdriver blade under a corner of the switch and **gently** pry it up. The switch has been glued to the valve and it may be necessary to break the switch. Clean the area where the old switch was removed, making sure it is smooth.
2. Place the switch in the area the old switch was removed from. Be sure to close the valve fully.
3. As you move the switch, the LED light should come on and go off. NOTE: *The switch is "normally on" so it should stay lit until it comes in contact with the internal magnet at which time the LED light will go out.*
4. Attach switch to valve using a drop of ABS glue.
5. Run the wires through the hole in the bracket under the motor housing. Attach leads to the wires that the old switch was connected to.

Care and Installation

To insure Drain Master is installed correctly, a couple of differences exist between the manual style valves and the new Drain Master. Electric valves differ from manual valves in one very important way; the motor has a specific torque output, which is strong enough to open a holding tank, which is 10 feet in height. The manual valve relies on the person to provide the torque and that varies person to person. Installation becomes much more important because any undue stress created by over tightening the flange bolts or putting the associated plumbing in a bind requires more torque than the motor creates. When this happens the Drain Master will sound like it is running but won't open because the clutch inside starts to slip (instead of stripping the gears). Until this undue stress is relieved either by loosening the bolts or taking the stress off the flanges, the valve will not function as intended.

By purchasing the Drain Master with the flanges attached to the valve, the seal is in the correct position and the flange bolts are torqued to the proper setting. (20"lbs.) This reduces installation time on the production floor.

The following list will help in obtaining a professional installation:

1. Valves and assemblies are tested for proper operation and for leaks before leaving our facility.
2. Valves should be kept in their individual packages until installation.
3. The 4 mounting bolts are torqued to 20 inch pounds.
4. Always follow all applicable codes and regulations.
5. When piping, extreme care must be taken not to put the valve in a bind or stressed position. This can cause undue pressure on plastic parts.
6. The valve should not support the piping. The valve should be in a relaxed state.
7. Care must be taken to keep the valve in a relaxed position when strapping or supporting the piping.
8. Do not install Drain Master against side walls-struts-cross members. This will cause vibration, along with difficulty, should servicing be needed.
9. The motor is always installed above the centerline of the pipe. The valve can be installed vertically.
10. Either side of the valve can be used as the pressure side (5 PSI Max).
11. Never flood test the system with the valve open.
12. The end user must easily access the manual override. The manual override must always be accessible and visible to the end user.
13. Tanks should be clean of all debris.

14. The valve should be easily accessible for service.
 15. Install valve as close as possible to tank. Installing the valve at the tank opening reduces the potential for tank blockages and keeps the valve away from damage.
 16. When gluing assemblies in place, care must be taken to not allow glue to come in contact with the gate, or valve body.
 17. Keep excess glue from collecting on valves and mounting bolts.
 18. All piping should be 3". Avoid the use of reducers. 3" valves on the gray tank speed the dumping time by 2.53 times (over 1.5" Valve) and helps keep tank cleaner.
 - 19. Always test valve operation before installation. Simply cycle a couple of times using a 12vdc battery. Reverse the red and white wires on the battery posts to open and close. Be careful to keep fingers away from the gate. IT WILL HURT YOU!! *Drain Master can supply a test transformer for on-line testing.***
 20. Never use the manual override for testing.
 21. The only recommended lubricant for the seals is Dow Corning 111. Call if you need some.
 22. Insure good electrical connections.
 23. Never use wire smaller than 20 gauge. Heavier gauge wire should be used for long runs to compensate for any voltage drop.
 24. Valve runs on 12 Volts DC only.
 25. As with all DC battery operated devices, best performance is achieved with a fully charged battery or the use of a generator. Discharged batteries will cause the valve to be sluggish or even fail to operate.
 26. Unless our Heavy Duty LED switch is installed, switches are not waterproof or watertight. Non Heavy Duty led switches must be installed in a dry location.
 27. If using your own switch, momentary contacts must be used.
- ❑ Fuse: Drain Master must be properly fused. When using blade type automotive fuses, a 5.0 Amp fuse must be used. If glass type fuse is used, MDL-5 or equal must be used. (See page 8 for wiring diagram)
 - ❑ Re: valves with Magnetic Switches- Because of the high number and proximity to equipment capable of generating stray current surges, it is highly recommended that we review a few installation guidelines to help prevent damage to the magnetic switch used to monitor the valve gate position.
 - Wire runs from the rear to the front of the vehicle should be kept as short and as straight as possible.
 - Care should be taken to route connecting wire away from existing wiring and away from pump, blower or inductive type motors and spark plugs.
 - Persistent problems may require a shielded and grounded wire run from the back to the front of the vehicle.

Failure to follow the above procedures may void any warranty claims.

OPERATION

Congratulations on the purchase of your new recreational vehicle. Your RV comes equipped with Drain Master electric waste valves. We are confident that our product will be a true benefit to your future RVing experience.

- Your Drain Master is extremely easy to use and requires little maintenance.
- Before you use your Drain Master, make sure you are ready to empty your waste, i.e. sewer hose is hooked up.
- When you are ready to dump your waste, simply push the switch up toward the word “open” and watch for discharge down the sewer hose. If your valve is equipped with the **magnetic switch (LED Light) your light will come on.
The Drain Master will open in 1-2 seconds, which means you don’t have to hold the switch in the open position for more than 2 seconds.
- To close your valve, simply push the rocker switch to the “close” position. Again, the valve will close in 1-2 seconds. If equipped with LED, the light will go out when the valve is completely closed.
- The switch is a momentary center return (which means, when you release the switch, it will automatically return to off).
- Never hold the switch in the open or closed position for more than 5 seconds.
- **IMPORTANT:** Should you ever lose power to your RV; you can open or close the valve manually. To do this, use the provided 1/8” Allen wrench located on the back side of the valve. On either side of the Drain Master, you will see the words *Manual Override* on the upper center area. The words Open and Close with directional arrows provide directions in which you will turn the Allen wrench shaft in the middle of this wording. Turn in the direction you need. There will be resistance as you are overriding a safety clutch. Turn until the shaft stops. The gate will fully open or close with about a turn and a half with a 1/8” Allen wrench. When convenient, check and correct electrical problem. * (see attached picture, page 4)
- **NOTE:** *If your valve becomes sluggish, you may need to remove the valve and remove debris from the gate area. Change and lubricate the seals, (only the seals purchased from Drain Master will work with this valve, Part #DM30-SB). Lubricate the seals with Dow Corning 111 only. We also have a valve maintenance kit available for purchase, reference P/N DM30-VMK.*

****If your valve switch is not equipped with the LED switch version, an upgrade is available for purchase, part number #DM30-MSK. Please call the toll free number to verify your valve is upgradeable.**

Technical assistance available. Call toll free. Also visit www.drainmaster.com for troubleshooting guide.

A Word about the Sewer Hose

Your sewer hose is the most durable hose on the market today and should give you many years of trouble free service, with proper care. Waste Master 1 system comes standard with a Sewer Supreme hose (not repairable). If upgraded to Sewer Master – this hose is repairable, see following information for repair procedure.

Repair Procedure – (If system is equipped with Sewer Master Hose) **Important Note: Waste Master System comes standard with a Sewer Supreme hose – not repairable. Sewer Master hose is an option)**

Should the Sewer Master (optional) hose incur damage, a pinhole, cut or burn, etc it can be repaired.

1. First locate the source of the problem and mark it with a grease pencil, marker or tape.
2. Remove the hose from the coach. See details removing the Hose for Service.
3. Stretch the hose in the area of the problem.
4. With a sharp knife cut out the damaged area and use a pair of wire cutters to clip the wire.
5. Remove the extra brown plastic around the wire leaving the white plastic over the wire. This cleans up both ends of the hose.
6. Lay the hose out on a flat surface with the 2 cut ends facing each other.
7. Push the 2 ends together and turn them in opposite directions toward each other. One hose will start to turn into the other.
8. The hose going inside the other now needs to have some silicon-based lubricant sprayed on it so it will be easier to turn the hose.
9. Continue to turn the hose into each other until it stops turning. It will go in about 3 turns. You are done; the hose won't leak or come apart!

Removing the Hose Assembly for Servicing

Locate the end of the hose opposite the nozzle. It will be located on the passenger side of the coach directly opposite the nozzle enclosure on the driver's side of the RV. A white sleeve will be over the actual fittings. Slide it back over the storage tube exposing the 3" fittings. Using a strap wrench unscrew the male fitting which is attached to the hose. When undone go to the drivers side of the coach, open the enclosure door and pull the nozzle and hose completely out of the compartment.

Installing the Hose Assembly

Insert the opposite end of the hose assembly, the male 3" fitting into the enclosure and continue to push the hose in until it reaches the female fitting on the passenger side of the RV. Coat the male threads with pipe dope, and then screw the fittings together until tight and leak free.

For additional information or questions before beginning, please call our toll free # 877 787 8833.

Field Changing Of Waste Master Nozzle

Materials:

Silicone caulking – not included

Tie wraps – included

Nozzle – included

Remove existing hose from the nozzle by cutting the hose approximately 2" from the end – this will clear the existing fitting. The best way to make the cut is to place the blade next to one of the wires and cut around the hose following the wire. Once you have cut around the wire, you will have to cut the wire with a pair of wire cutters. Please note: Tin snips will not make this cut!

Extend the hose approximately 4" from the end. Using silicone caulk – approximately ¼" thick bead on the inside of the hose following the helical wire until one complete revolution is made.

Take the new nozzle and move the handle to the "open" position.

Insert barbed fitting completely into the extended hose.

Install the tie wrap around the hose and barbed fitting. The arch at the head of the tie wrap must straddle a wire on the hose. Pull the tie wrap tight, and cut off the excess.

Allow the silicone caulk to "cure" following instructions on the container, typically 24 hours.

OEM Warranty

For customer service, technical assistance or to obtain a return authorization number, call 1 (877) 787-8833. Fax: (831) 636-3759 E-mail: [OEMSERVICE@DRAINMASTER.COM](mailto: OEMSERVICE@DRAINMASTER.COM) Address for returns: Drain Master LLC, O.E. Customer Service Dept., 1803 Shelton Drive Ste. 102, Hollister, CA 95023

Information about Returns

The Drain Master commitment is to have satisfied customers. Occasionally it may be necessary to return parts to PFI. This policy covers most return situations. The conditions are designed to be fair to our customers and provide internal cost control so we can maintain our value pricing.

If we make a mistake with your order, we apologize for the inconvenience. Please call us, and we will ship the correct items immediately. DM will provide merchandise credit upon receipt of the returned material.

If you return product within 30 days, there is a 25% inspection and restocking charge. DM will credit your account provided that the returned items are in sellable condition.

No products will be accepted for return after 31 days from date of invoice. These conditions apply to items returned in new condition, original packaging and undamaged.

Special orders and dedicated inventory:

Orders for products which are specially fabricated to the Purchasers specifications or request may not be modified, cancelled or returned by the Purchaser. The Purchaser covenants to indemnify DM from any loss arising from such action by the Purchaser. Dedicated inventory constitutes product which DM keeps on hand to service the Purchaser. This includes products built to the Purchasers specifications and all parts that DM stocks to build such products. Purchaser shall always be responsible for timely relieving Seller of all such inventory in accordance with the agreed upon schedule.

Warranty

Returns involving warranty claims

The time period for the Waste Master warranty is equivalent to the coach manufacturer's limited warranty, (not the chassis warranty) and is guaranteed to be free of mechanical defects in material and workmanship. In order for a claim to be honored, DM must be provided with coach number, customer information, date of purchase, if applicable, dealer service report and complete description of problem.

During the warranty period DM will replace the product only if deemed defective due to mechanical defect in material and workmanship, which will be your exclusive remedy under this warranty. Drain Master shall not be liable for any special, incidental, indirect or consequential damages whatsoever (including, without limitation, labor or installation charges, damages for loss of business profits, business interruption or any other pecuniary loss) arising out of the use of or inability to use the product.

- ❑ Proper installation procedures **must** be followed for the warranty to be valid.
- ❑ The faulty product must be returned, freight pre paid, to PFI for inspection before replacement product will be sent to you.
- ❑ If your warranty dept. is separate from production / manufacturing, you will need to purchase warranty replacement product in advance.
- ❑ You must call for a **Return Authorization Number** before sending product back to Drain Master.
- ❑ The warranty does not cover inbound freight. It does cover outbound freight of the replacement product.